

# OSSTEM IMPLANT SYSTEM

2012 PRODUCT CATALOG



for **KIT & GBR**

<b>KIT</b>	<b>09</b> Taper KIT	<b>10</b> New Hanaro KIT	<b>12</b> Taper Simple KIT	<b>13</b> 123 KIT
<b>14</b> Ultra KIT	<b>15</b> Taper Ultra KIT	<b>16</b> Drills	<b>19</b> Drill for Ultra-Wide Taper Drill	<b>20</b> Guide Drills
<b>20</b> Sidecut Drill	<b>20</b> Drill Extension	<b>21</b> Long Shank Pilot Drill	<b>21</b> Cortical Drill 2 for TSII, SSII SA	<b>21</b> Cortical Drill 3 for Taper Fixture
<b>22</b> Taper Cortical Drill for Taper Fixture	<b>22</b> Cortical Drill for Ultra-Wide	<b>22</b> Long Shank Countersink for SSII RBM	<b>22</b> Countersink for USII RBM	<b>23</b> Countersink for USIII
<b>23</b> Surgical Tap for SSII RBM	<b>23</b> Surgical Tap for USII RBM	<b>23</b> Parallel Pin	<b>24</b> Parallel Pin for 123 drill	<b>24</b> Depth Gauge
<b>24</b> Ultra Wide Trial Pin	<b>25</b> Depth Gauge Pin for SSII RBM	<b>25</b> Depth Gauge Pin for USII RBM	<b>25</b> Positioning Guide	<b>26</b> TS Tissue Height Gauge
<b>26</b> Torque Wrench (Bar type)	<b>26</b> Ratchet Wrench	<b>27</b> TS NoMount Driver	<b>27</b> SS NoMount Driver	<b>27</b> US NoMount Driver
<b>28</b> TS NoMount Torque Driver	<b>28</b> SS NoMount Torque Driver	<b>28</b> TS Fixture Driver	<b>29</b> SS Fixture Driver	<b>29</b> Simple Mount Driver
<b>30</b> Simple Mount Extension	<b>30</b> Simple Open Wrench	<b>30</b> Removal Tool for Fixture Mount	<b>31</b> Tissue Punch	<b>31</b> TS Bone Profiler

# OSSTEM HISTORY

 32 US Bone Profiler	 32 Trepine Drill	 32 Bone Mill	 33 Prosthetic KIT	 34 TS Prosthetic KIT
 35 Hand Driver	 35 Machine Screw Driver	 36 O-ring Abutment Driver	 36 Rigid Outer Driver	 37 Solid Abutment Driver
 37 Excellent Solid Abutment Driver	 37 Octa Abutment Drive	 38 OSSTEM Torque Driver	 38 Path Probe for GS, TS	 38 Connector
 39 Driver Handle	 39 Dalbo Plus Screw Driver	 39 Finishing Reamer Set	 40 Reamer Bite	 40 Reamer Tip
 41 CAS-KIT	 42 CAS Drill	 42 Stopper	 43 LAS-KIT	 45 MS KIT
 46 Ortho KIT	 47 Bone Screw KIT	 48 Custom KIT	 49 Osteo KIT	 50 Osteotome KIT
 51 Sinus KIT	 53 Bone Spreader KIT	 54 Ridge Split KIT-Straight	 55 Ridge Split KIT-offset	 56 OsstemGuide KIT
 61 Screw removal KIT	 62 Reverse Driver	 62 Guide	 62 Screw Holder	 63 Re-tap
 63 ABT Removal Tool ABT Removal Tip	 64 Slot Driver	 64 Torque Handle	 64 Removal Bur	 65 Screw Remover

2011	Dec	Introduces and commences commercial production of K2 Unit & Chair	2007	Mar	Develops and begins commercial production of MS Lists on KOSDAQ (KRX: Korea Exchange)					
	Nov	Develops and begins commercial production of Smart Membrane		2006	Dec	Establishes subsidiary offices in Bangkok, Thailand and Kuala Lumpur, Malaysia [OSSTEM Thailand Co., Ltd. and OSSTEM Malaysia SDN, BHD]				
	Oct	Registers and obtains approval from Health Canada Develops and begins commercial production of USII SA and 123 Kit			Nov	Registers and obtains approval from the SFDA in China				
	Sep	Establishes subsidiary offices in Dacca, Bangladesh and Ho Chi Minh City, Vietnam [OSSTEM Bangladesh Ltd. and OSSTEM IMPLANT Vina Co., Ltd.] Develops and begins commercial production of SSIII SA Registers and obtains approval from the Ministry of Health and Society in Vietnam			Sep	Establishes subsidiary office in Philadelphia, U.S.A [HiOssen Inc.]				
	Aug	Establishes subsidiary offices in Manila, Philippines and Vancouver, Canada [OSSTEM Philippines Inc. and HiOssen Implant Canada Inc.]			Aug	Establishes subsidiary offices in Beijing, China / Singapore and Hong Kong [OSSTEM China Co., Ltd. / OSSTEM Singapore Pte Ltd. and OSSTEM Hong Kong Ltd.]				
	Jul	Develops and begins commercial production of CustomFit Abutment Establishes subsidiary offices in Almaty, Kazakhstan [OSSTEM IMPLANT LLP]			Jul	Establishes subsidiary office in Tokyo, Japan [OSSTEM Japan Corp.]				
	Jun	Develops and begins commercial production of TSII SA Hosts 'OSSTEM World Meeting 2011 in Seoul'			Apr	Registers and obtains the GOST-R certification in Russia Opens 'OSSTEM World Meeting 2006 in Seoul' Publishes the '2006 OSSTEM IMPLANT SYSTEM' - Introduction and particulars of implant system				
	Apr	Develops and begins commercial production of LAS Kit Establishes subsidiary offices in Jakarta, Indonesia [PT OSSTEM Indonesia]			Jan	Establishes the subsidiary offices in Moscow, Russia and Mumbai, India [OSSTEM LLC. and OSSTEM IMPLANT India Pvt Ltd.]				
	Mar	Establishes subsidiary offices in Guadalajara, Mexico [HiOssen de Mexico]			2005	Dec	Registers and obtains approval by the DOH in Taiwan Establishes the subsidiary office in Ashborn, Germany [OSSTEM Germany GmbH]			
	Feb	Develops and begins commercial production of TSIV SA				May	Develops and begins commercial production of GSII			
2010	Nov	Develops and begins commercial productions of SSII SA	Apr			Hosts 'OSSTEM World Meeting 2005 in Seoul'				
	Aug	Develops and begins commercial productions of TSIII Ultra-wide	Mar	Obtains KGMP(Korean Good Manufacturing Practice) in Korea						
	Jun	Develops and begins commercial productions of TSIII HA and CAS Kit Opens 'OSSTEM World Meeting 2010 in Beijing'	Jan	Establishes the subsidiary office in Taipei, Taiwan [OSSTEM Corporation]						
	Apr	Develops and begins commercial productions of Osstem Guide	2004	Nov		Develops and begins commercial production of SSIII				
	Mar	Develops and begins commercial productions of TSIII SA		Jul		Develops and begins commercial production of USIII				
	2009	Oct		Registers and obtains approval from Health, Labor and Welfare in Japan		Apr	Opens 'OSSTEM World Meeting 2004 in Seoul'			
		May		Hosts 'OSSTEM World Meeting 2009 in Bangkok'		2002	Oct	Develops and begins commercial production of SSII		
		Jan		Certifies PEP7 (the world's first new Osseo-inductive compound)			Aug	Registers and obtains approval by the FDA in the USA Develops and begins commercial production of USII		
		2008		Nov	Develops and begins commercial productions of SS Ultra-wide		Jan	Establishes OSSTEM Implant R&D Center		
				Jun	Develops and begins commercial productions of GSIII		2001	Mar	Establishes AIC(Apsun Dental Implant Research & Education Center)	
Apr				Hosts 'OSSTEM World Meeting 2008 in Seoul'	Jan			Obtains CE-0434 certification		
Mar				Opens ATC Training Center	1999			Dec	Obtains ISO-9001 certification	
Jan				Establishes OSSTEM Bone Science Institute				1997	Dec	Begins commercial production under the brand name of OSSTEM
2007			Oct	Establishes subsidiary offices in Sydney, Australia [Osstem Australia PTY Ltd.]					Jan	Establishes OSSTEM IMPLANT Co., Ltd. in Seoul, Korea
			Jun	Registers and obtains approval from the TGA in Australia					1995	Develops dental implants and acquires industrial license
	May		Develops and begins commercial production of US Ultra-wide	1992						Initiates the development of dental implant system
	Apr		Hosts 'OSSTEM World Meeting 2007 in Seoul' Begins commercial production of V-ceph							

# OSSTEM IMPLANT SYSTEM

## KIT

Fixture and Restorative  
Components



Early & Esthetic  
**OSSTEM IMPLANT**

**KIT**

## New Product

Name	Code	Image	Page
123 Kit	H123K		P 13
Taper Ultra Kit	HULTPK		P 15
LAS-KIT Plus	HLRSNKP		P 44

## Upgraded Products

Name	Code	Image		Improvements	Page
		Before	After		
Machine Screw Driver	AMSD09S, AMSD09L, AMSD12S, AMSD12L, AMSD12E			Improvement of holding function	P 35
OSSTEM Torque Driver	OTH12S			Improvement of holding function	P 38
Taper Cortical Drill	TCD4C35, TCD4C40, TCD4C45, TCD4C50			Optimization of Taper Cortical Drill diameter	P 22

## Taper KIT (OTSK)

Use range (Use )

USII	SSII	GS/TSII	Ultra-wide	MS	OS
USIII	SSIII	GS/TSIII			

**Twist Drill**  
TDE2008LC01  
TDE2010LC01  
TDE2011LC01  
TDE2013LC01  
TDE2015FNLC01

**Ø 3.0 Twist Drill**  
3D3011LC02  
3D3015FNLC02

**Ø 3.5 Taper Drill**  
TPD3C3507  
TPD3C3508  
TPD3C3510  
TPD3C3511  
TPD3C3513  
TPD3C3515

**Ø 4.0 Taper Drill**  
TPD3C4007  
TPD3C4008  
TPD3C4010  
TPD3C4011  
TPD3C4013  
TPD3C4015

**Ø 4.5 Taper Drill**  
TPD3C4507  
TPD3C4508  
TPD3C4510  
TPD3C4511  
TPD3C4513  
TPD3C4515

**Ø 5.0 Taper Drill**  
TPD3C5007  
TPD3C5008  
TPD3C5010  
TPD3C5011  
TPD3C5013  
TPD3C5015

**Guide Drill**  
AGDLC

**SideCut Drill**  
OSLMD20L

**Drill Extension**  
ADE

**Parallel Pin**  
APP400: 2ea  
APP500: 2ea

**Hand Driver**  
AHD12SH  
AHD12LH

**Torque Driver**  
TRHD12S  
TRHD12L

**Simple Mount Driver**  
ASMDS  
ASMDL

**Simple Mount Extension**  
ASMES  
ASMEL

**Removal Tool for Mount**  
HRFR

**Taper Cortical Drill**  
TCD4C35  
TCD4C40  
TCD4C45  
TCD4C50

**NoMount Driver**  
GSNMD32L  
GSNMD35L

**TS Fixture Driver**  
GSMFDL  
GSRGDL

**Ratchet Wrench**  
CITOW-1185A

**Depth Gauge**  
ADG

**Open Wrench**  
ASOW  
(Components of lower plate)

# New Hanaro KIT (HKA2)

Use range (Use  )

USII	SSII	GS/TSII	Ultra-wide	MS	OS
USIII	SSIII	GS/TSIII			

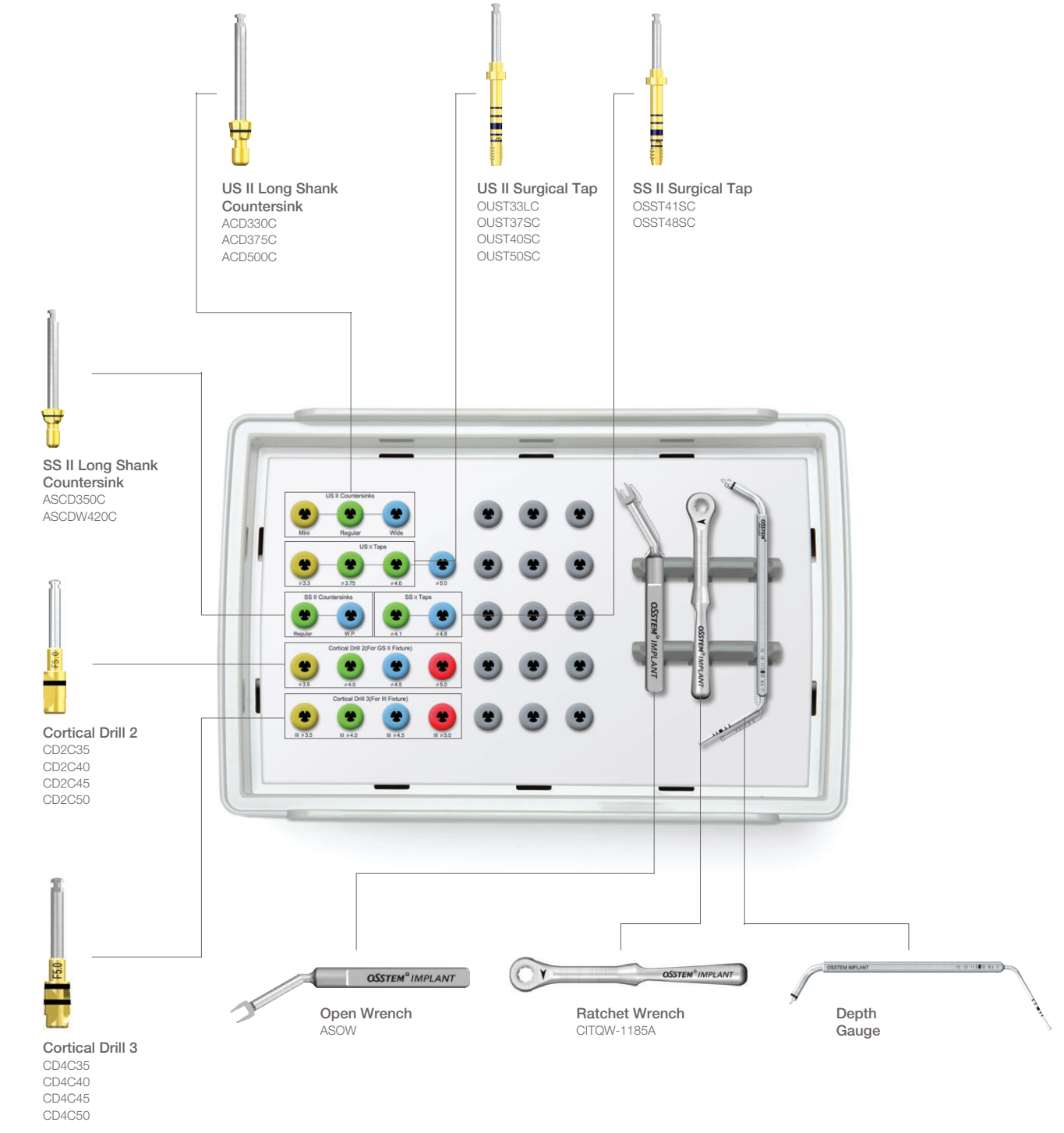
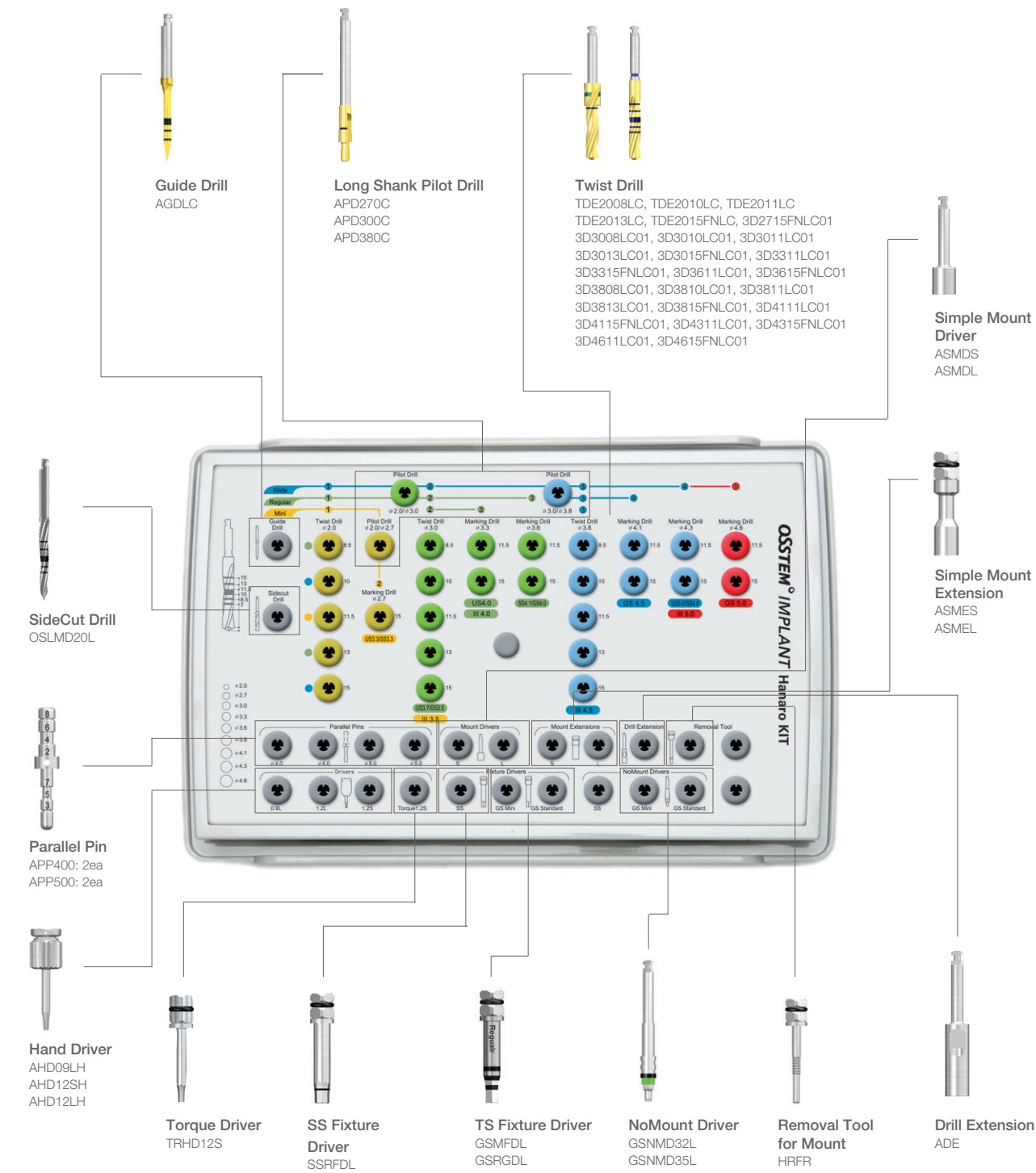

# Taper Simple KIT (OTSSK)

Use range (Use )

USII	SSII	GS/TSII	Ultra-wide	MS	OS
USIII	SSIII	GS/TSIII			

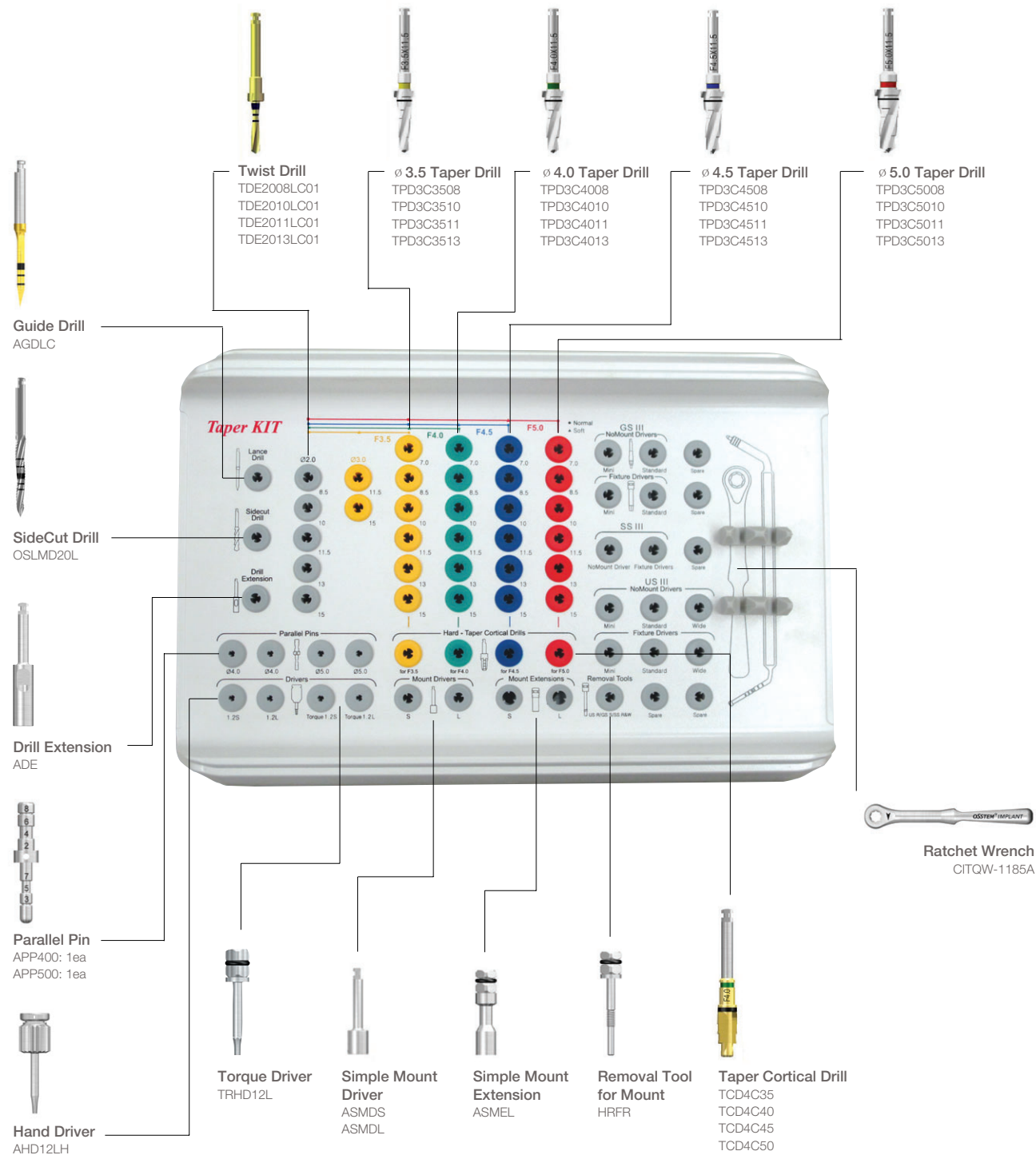

# 123 KIT (H123K)

Use range (Use )

TSII SA	SSII SA	USII SA	Ultra-wide	MS	OS
TSIII SA/HA	SSIII SA	USIII SA			

(\* Use 123KIT for SA or HA surface-treated fixture only)

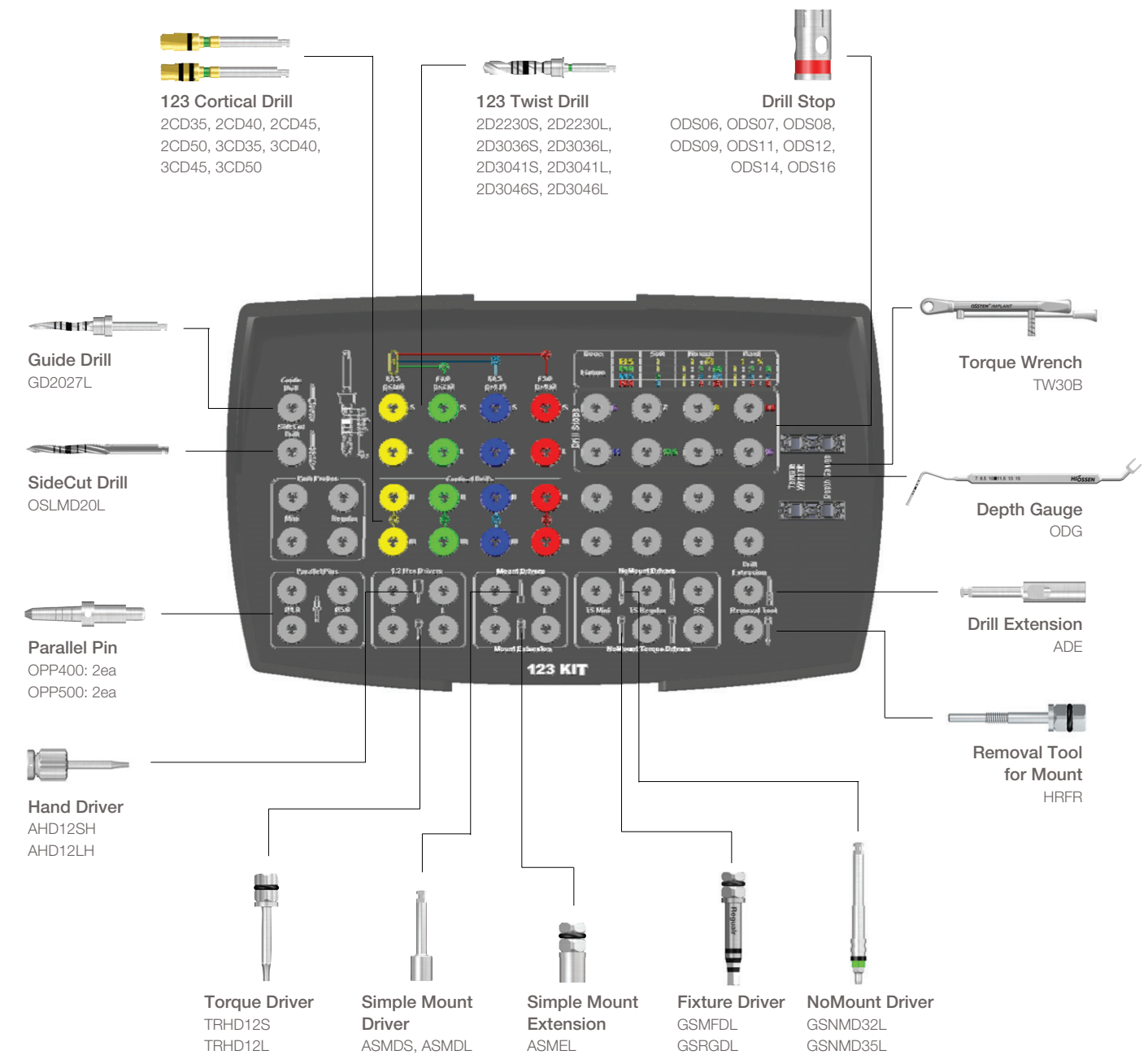

# Ultra KIT (HULTRK)

Use range (Use ■)

USII	SSII	TSII	Ultra-wide	MS	OS
USIII	SSIII	TSIII			

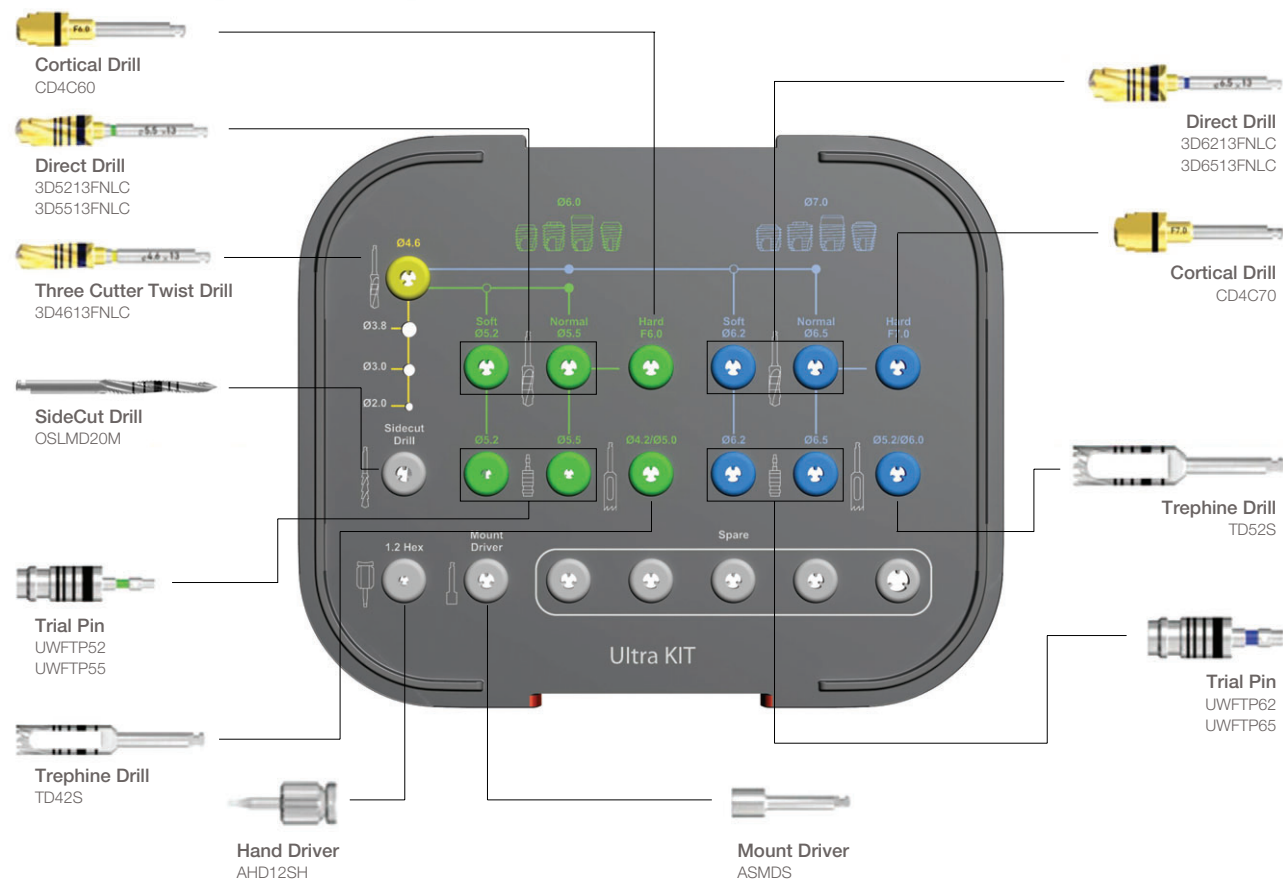

# Taper Ultra KIT (HULTPK)

Use range (Use ■)

USII	SSII	TSII	II Ultra-Wide	MS	OS
USIII	SSIII	TSIII	III Ultra-Wide		

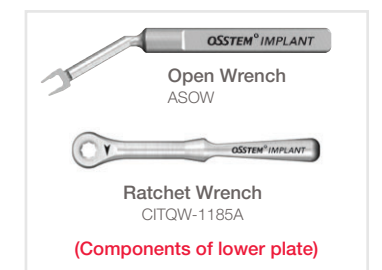



# Surgical Instruments for OSSTEM IMPLANT

## Drill selection tip according to anatomy condition

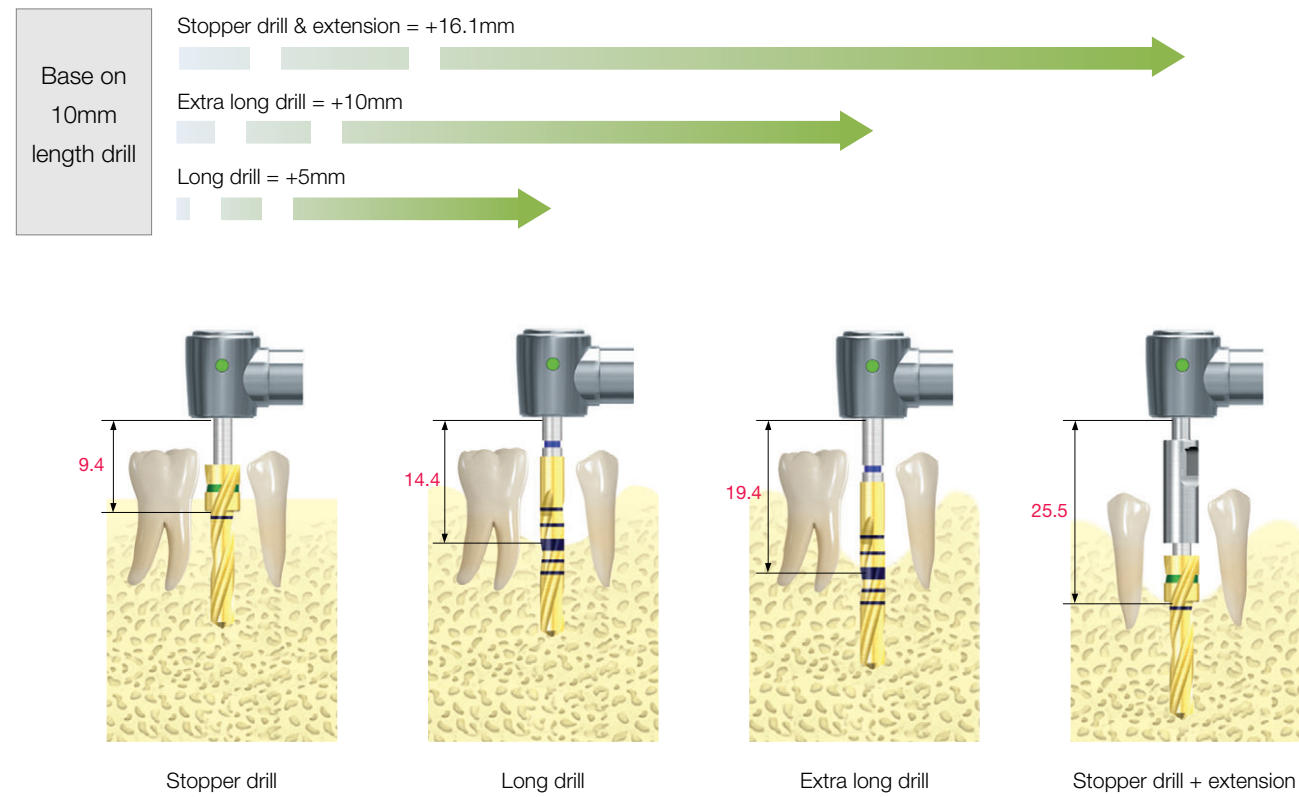

## General length markings of OSSTEM equipment and the tip length of the twist drill

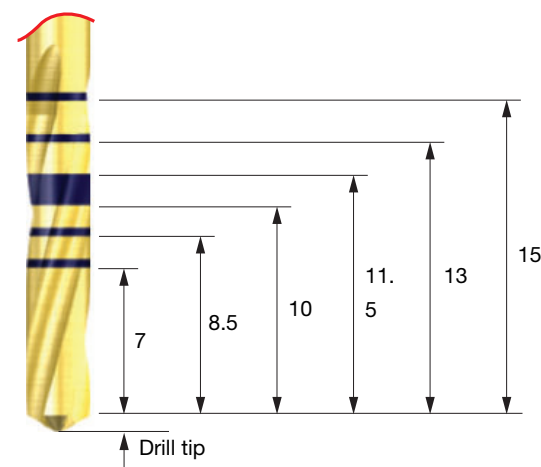

General length marks of OSSTEM tools  
Based on the thick marking line (10 and 11.5mm), upper 13 and 15mm and lower 7 and 8.5mm positions are marked

Drill diameter	Drill tip size
φ 2.0mm	0.6mm
φ 2.7mm	0.8mm
φ 3.0mm	0.9mm
φ 3.3mm	1.0mm
φ 3.6mm	1.0mm
φ 3.8mm	1.0mm
φ 4.1mm	1.0mm
φ 4.3mm	1.0mm
φ 4.6mm	1.0mm

# Surgical Instruments for OSSTEM IMPLANT

## Twist Drills

### Stopper Drill

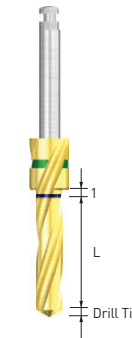

### Long Drill

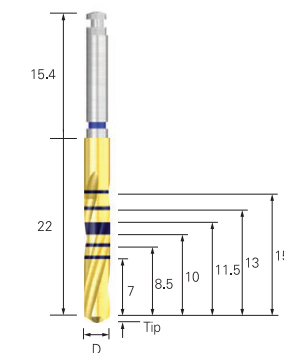

### Extra Long Drill

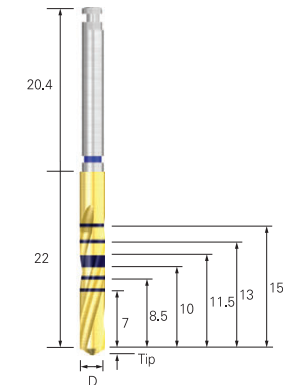

### Stopper Drill

L	D	φ 2.0	φ 3.0	φ 3.3	φ 3.6	φ 3.8	φ 4.1	φ 4.3	φ 4.6
7		TDE2007LC	3D3007LC01	-	-	3D3807LC01	-	-	-
8.5		TDE2008LC	3D3008LC01	-	-	3D3808LC01	-	-	-
10		TDE2010LC	3D3010LC01	-	-	3D3810LC01	-	-	-
11.5		TDE2011LC	3D3011LC01	3D3311LC01	3D3611LC01	3D3811LC01	3D4111LC01	3D4311LC01	3D4611LC01
13		TDE2013LC	3D3013LC01	-	-	3D3813LC01	-	-	-

• Package unit : each part

- Long stopper (6 mm) : Posterior surgery may be performed even without drill extension
- The color coding on the stopper indicates the drill length
- The tip length of a 2.0 twist drill is 0.6 mm, and the other tip length of drills, 0.8mm~1mm

### Long Drill

L	D	φ 2.0	φ 2.7	φ 3.0	φ 3.15	φ 3.3	φ 3.6	φ 3.8	φ 4.1	φ 4.3	φ 4.6
13		TDE2013FNLC		3D3013FNLC				3D3813FNLC			3D4613FNLC
15		TDE2015FNLC	3D2715FNLC01	3D3015FNLC01	3D3115FNLC01	3D3315FNLC01	3D3615FNLC01	3D3815FNLC01	3D4115FNLC01	3D4315FNLC01	3D4615FNLC01

• Package unit : each part

- Cuts the stopper of a 15 mm drill to facilitate depth adjustment in the ridge
- The laser marking indicates the length, thereby enabling all drilling lengths (7-15 mm) using one drill
- Handles are color-coded to indicate drill length

### Extra Long Drill

L	D	φ 2.0	φ 2.7	φ 3.0	φ 3.15	φ 3.3	φ 3.6	φ 3.8	φ 4.1	φ 4.3	φ 4.6
		TDE2015FNEC	3D2715FNEC	3D3015FNEC	3D3115FNEC	3D3315FNEC	3D3615FNEC	3D3815FNEC	3D4115FNEC	3D4315FNEC	3D4615FNEC

• Package unit : each part

- For sufficient intermaxillary gap as in the anterior part, drilling may be performed even without drill extension
- The laser marking indicates the length, thereby enabling all drilling lengths (7-15 mm) using one drill
- Handles are color-coded to indicate drill length

### 123 Twist Drill

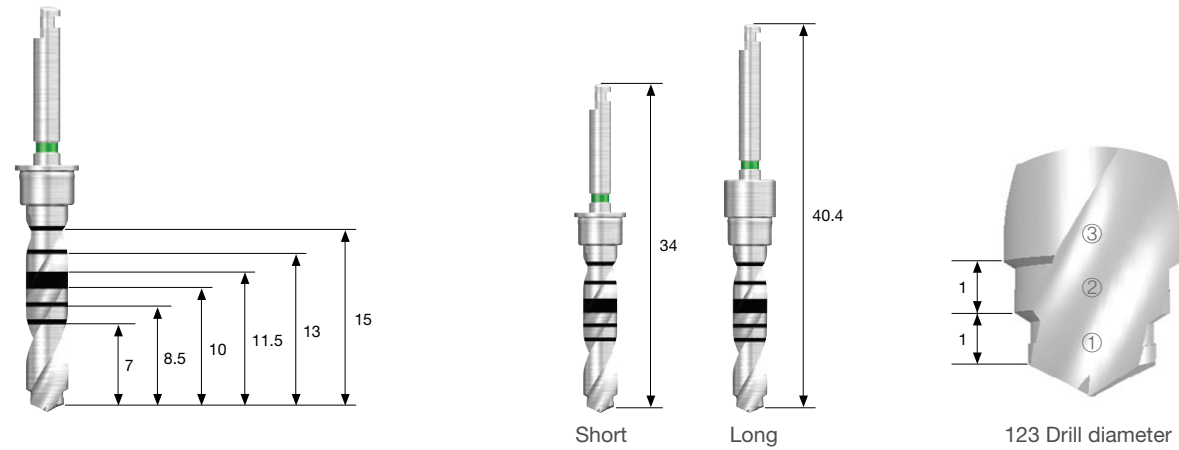

①/ ②/ ③	ø 2.2/3.0	ø 3.0/3.6	ø 3.0/3.6/4.1	ø 3.0/4.1/4.6
Short	2D2230S	2D3036S	2D3041S	2D3046S
Long	2D2230L	2D3036L	2D3041L	2D3046L
Coloring	Yellow	Green	Blue	Red
Y-Dim.	0.7mm			

- Packing unit: each part
- The color of 123drill handle part means the diameter and kind of main mixture to be used  
- Yellow: F3.5, Green: F4.0, Blue: F4.5, Red: F5.0
- Install the drill stop in order to adjust the drilling depth to intended level
- 123 twist drill has good cutting force and control of drilling depth may be difficult; therefore, it is highly recommended to use the drill stop

### 123 Drill Stop



	ODS06	ODS07	ODS08	ODS09	ODS11	ODS12	ODS14	ODS16
L(mm)	6.2	7	8	9.5	11	12.5	14	16
Coloring	Purple	White	Yellow	Red	Blue	Green	Black	Purple

- Packing unit: each part
- The length of drill stop means the remained actual length when the drill stop is installed on 123 twist drill
- The lengths are differentiated with colors for convenient identification of lengths and return to KIT

### Drill for Ultra-Wide

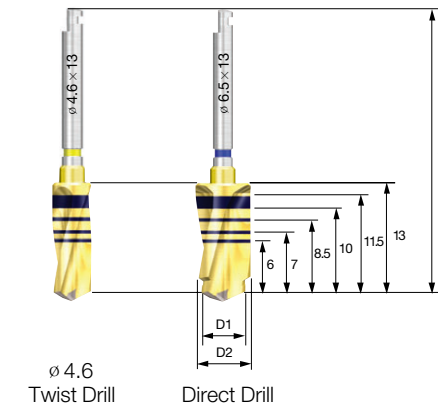

Name	D1	D2	Code
ø 4.6 Twist Drills	ø 4.6	-	3D4613FNLC
ø 5.2 Direct Drill	ø 4.6	ø 5.2	3D5213FNLC
ø 5.5 Direct Drill	ø 4.6	ø 5.5	3D5513FNLC
ø 6.2 Direct Drill	ø 5.5	ø 6.2	3D6213FNLC
ø 6.5 Direct Drill	ø 5.5	ø 6.5	3D6513FNLC

- Direct drill: 2-stepped drill equipped with both pilot and twist drill function
  1. Enables final drilling without pilot drilling
  2. Enhancement of initial fixation in the extract socket by decreasing the dead space at the apex area

### Taper Drill

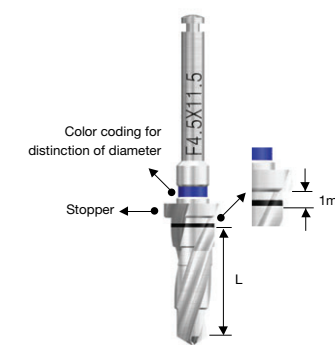

L	Spec.	ø 3.5	ø 4.0	ø 4.5	ø 5.0
7	TPD3C3507	TPD3C4007	TPD3C4507	TPD3C5007	
8.5	TPD3C3508	TPD3C4008	TPD3C4508	TPD3C5008	
10	TPD3C3510	TPD3C4010	TPD3C4510	TPD3C5010	
11.5	TPD3C3511	TPD3C4011	TPD3C4511	TPD3C5011	
13	TPD3C3513	TPD3C4013	TPD3C4513	TPD3C5013	
15	TPD3C3515	TPD3C4015	TPD3C4515	TPD3C5015	

Length of Drill Tip	0.8mm	0.9mm	1.0mm	1.0mm
---------------------	-------	-------	-------	-------

- Packing Unit : each part
- Processing exclusive use Taper Drill for Ill fixture diameter and length
- Stopper drill with 1mm margin
- Color coding on the shank indicates the fixture diameter  
(ø 3.5:Yellow, ø 4.0:Green, ø 4.5:Blue, ø 5.0:Red)

### Taper Ultra Drill

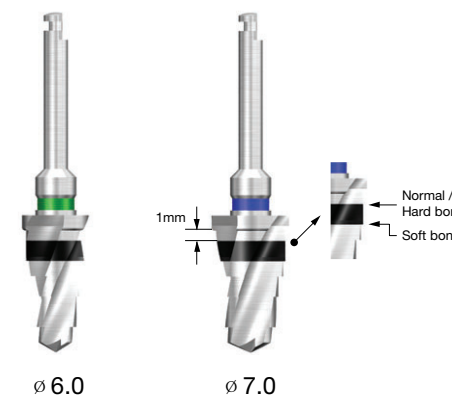

L	Spec.	ø 6.0	ø 7.0
6	TPD3C6006	TPD3C7006	
7	TPD3C6007	TPD3C7007	
8.5	TPD3C6008	TPD3C7008	
10	TPD3C6010	TPD3C7010	
11.5	TPD3C6011	TPD3C7011	
13	TPD3C6013	TPD3C7013	

- Packing Unit : each part
- Processing exclusive use Taper Drill for Taper Ultra-Wide fixture diameter and length
- Stopper drill with 1mm margin
- Color coding on the shank indicates the fixture diameter  
(ø 6.0 : Green, ø 7.0 : Blue)

# Surgical Instruments for OSSTEM IMPLANT

## Lance Drill: Guide Drill

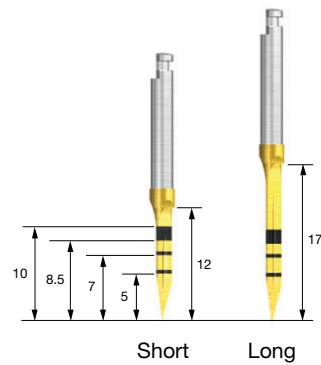

Type	Code	
Lance Drill	Short	AGDSC
Lance Drill	Long	AGDLC

- Packing Unit : each part
- Forms holes in the bone to facilitate initial drilling
- Bone density can be determined through drilling
- TiN coating improves anti-corrosion and wear resistance

## Guide Drill

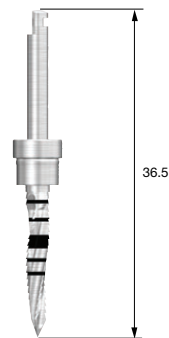

Code	φ 2.0
Code	GD2027L

- Packing Unit : each part
- Used as the initial drill
- Install the drill stop in order to adjust the drilling depth to intended level

## Sidecut Drill

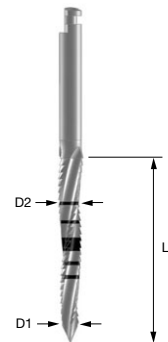

	D1	D2	L
OSLMDS	1.5	2.0	13.0
OSLMDL	1.5	2.0	20.0
OSLMD20S	2.0	2.5	13.0
OSLMD20L	2.0	2.5	20.0

- Packing Unit : each part
- Enables the bodily change of drilling direction
- Used to cut the ridge of the extracted socket
- Facilitates site preparation in the extracted socket

## Drill Extension

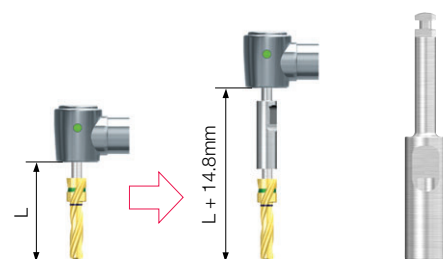

14.8mm extension of drill length in case of using drill extension

Code	ADE
Code	ADE

- Packing Unit : each part
- Extends the length a drill and other hand tools
- Insertion into an O-ring offers a holding function
- Use by connecting the flat side of the drill handle to the flat side of the drill extension
- The use of too much force is prohibited

## Long Shank Pilot Drill

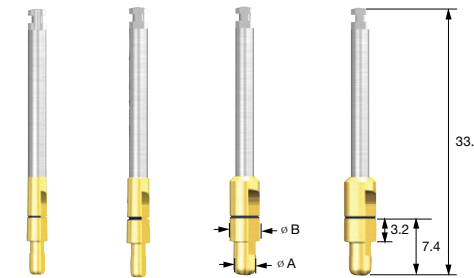

φ A	φ B	Mini	Regular	Wide
2.0	2.7	APD270C	-	-
2.0	3.0	-	APD300C	-
3.0	3.8	-	-	APD380C
3.0	4.1	-	-	APD410C

- Packing Unit : each part
- Used for the path adjustment of a drilling hole
- When using the next size drill, the guide hole enables precise cutting
- TiN coating improves anti-corrosion and wear resistance

## 123 Cortical Drill

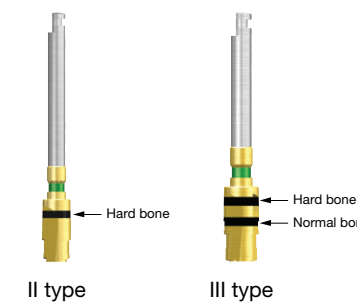

	F3.5	F4.0	F4.5	F5.0
II type	2CD35	2CD40	2CD45	2CD50
III type	3CD35	3CD40	3CD45	3CD50
Coloring	Yellow	Green	Blue	Red

- Packing Unit : each part
- It is recommended to drill up to the lower end of the marking line
- The marking line of II type cortical drill is based on hard bone
- The lower end marking line of III type cortical drill is based on normal bone and the upper end marking line is based on hard bone
- The color of handle part means the diameter and kind of main mixture to be used
- Yellow: F3.5, Green: F4.0, Blue: F4.5, Red: F5.0

## Cortical Drill 2 for TSII, SSII SA



Spec.	φ 3.5	φ 4.0	φ 4.5	φ 5.0
Code	CD2C35	CD2C40	CD2C45	CD2C50

- Packing Unit : each part
- Use after formation of final drill hole in case of hard bone(D1)
- Exclusive drills are available to meet the fixture diameters
- It is recommend that drilling performs up to under marking line

## Cortical Drill 3 for Taper Fixture (TSIII, SSIII, USIII)



Spec.	φ 3.5	φ 4.0	φ 4.5	φ 5.0
Code	CD4C35	CD4C40	CD4C45	CD4C50

- Packing Unit : each part
- Drills for expansion of cortical bone after use of straight drill
- Use after formation of final drill hole in case of more than normal bone
- Exclusive drills are available to meet the fixture diameters
- The lowest marking line is normal bone and the highest marking line is hard bone
- It is recommend that drilling performs up to marking line

# Surgical Instruments for OSSTEM IMPLANT

## Taper Cortical Drill for Taper Fixture (TSIII, SSIII, USIII)



Spec.	φ 3.5	φ 4.0	φ 4.5	φ 5.0
Code	TCD4C35	TCD4C40	TCD4C45	TCD4C50

- Packing Unit : each part
- Drills for expansion of cortical bone after use of taper drill
- Use after formation of final drill hole in case of more than hard bone
- Exclusive drills are available to meet the fixture diameters
- Lower end marking line is based on 8.5mm or smaller fixture implant  
Upper end marking line is based on 10mm or larger fixture implant
- It is recommend that drilling performs up to the bottom marking line

## Cortical Drill for Ultra-Wide®



Name	Code
F6.0 Cortical Drill	CD4C60
F7.0 Cortical Drill	CD4C70

- Use after formation of final drill hole in case of hard bone(D1)
- Exclusive drills are available to meet the fixture diameters
- It is recommend that drilling performs up to the bottom marking line

## Long Shank Countersink for SSII RBM

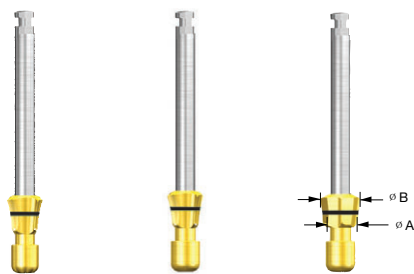

φ A	φ B	Regular φ 4.1	Regular φ 4.8	Wide φ 4.8
3.5	4.8	ASCD350C	-	-
4.2	4.8	-	ASCD420C	-
4.2	6.0	-	-	ASCDW420C

- Packing Unit : each part
- Form fixture platform
- Cut up to the bottom of the laser marking
- Use US Mini Countersink for SS Mini as needed

## Long Shank Countersink for USII RBM

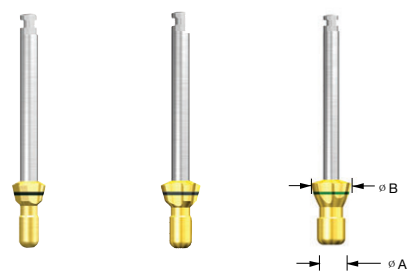

φ A	φ B	Mini	Regular	Wide
2.6	3.5	ACD330C	-	-
2.9	4.1	-	ACD375C	-
4.2	5.1	-	-	ACD500C

- Packing Unit : each part
- Form space of fixture flange
- Cut up to the bottom of the laser marking

## Countersink for USIII, USII SA, USIII SA(Wide PS, Wide)



Code	USSCS45W
------	----------

- Packing Unit : each part
- Instruments for Wide PS, Wide of USIII, USII SA, USIII SA
- Recommendation drilling rpm : 300rpm

## Surgical Tap for SSII RBM



Platform	φ 4.8	φ 4.8	φ 6.0
Type D	φ 4.1	φ 4.8	
Short	OSST41SC	OSST48SC	
Long	OSST41LC	OSST48LC	

- Packing Unit : each part
- Use for dense bone and form screw thread-shaped fixtures
- Use a torque wrench after connecting to the engine or mount extension
- TiN coating improves anti-corrosion and wear resistance

## Surgical Tap for USII RBM



Type	D	3.3	3.75	4.0	5.0
Short		-	OUST37SC	OUST40SC	OUST50SC
Long		OUST33LC	OUST37LC	OUST40LC	-

- Packing Unit : each part
- Use for dense bone and form screw thread-shaped fixtures
- Use as a torque after connecting to the engine or a simple mount extension
- TiN coating improves anti-corrosion and wear resistance

## Parallel Pin

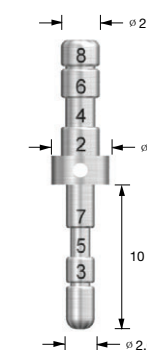

Diameter(φ)	Code
φ 4.0	APP400
φ 5.0	APP500
φ 6.0	APP600
Full Set	APPS

- Packing Unit : Individual and general set packing
- Use for checking the direction and location for bone preparation
- Predicts the diameter of an abutment to be secured

## Parallel Pin for 123 drill

D	φ 4.0	φ 5.0
Code	OPP400	OPP500

- Packing Unit : each part
- Parallel Pin 123 Twist Drill only
- Use for checking the direction and location for bone preparation
- Use the lower part for initial drilling and higher part for F3.5 (φ 2.2/3.0) drilling

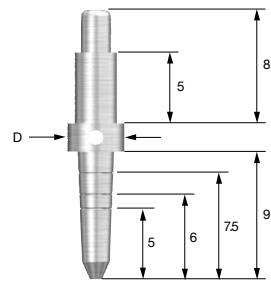

## Depth Gauge

Code	ADG
------	-----

- Packing Unit : each part
- A : Measurement of drilling length (7-15 mm)
- B : Measurement of gingival height following external fixture grafting



## Depth Gauge

Code	ODG
------	-----

- Packing Unit : each part
- Use as drilling depth measurement and open wrench
- Use for separating Mount in case of soft bone



## Trial Pin for Ultra-Wide

Diameter(D)	φ 5.2	φ 5.5	φ 6.2	φ 6.5
Code	UWFTP52	UWFTP55	UWFTP62	UWFTP65

- Packing Unit: each part
- Check internal width and depth after extraction of a tooth
- Check the drilling depth after using direct drill as final drill
- Verify the internal diameter of the failed implant socket.
- The purpose of Parallel Pin

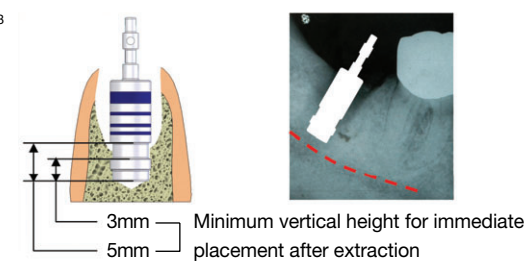
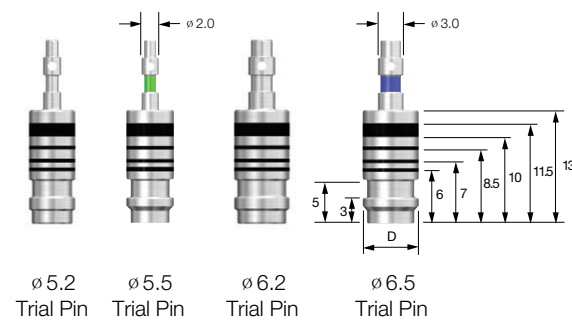

## Depth Gauge Pin for SSII RBM

Diameter(φ)	φ 3.6	φ 4.3
Code	ASDG360	ASDG430

- Packing Unit : each part
- Measure the depth after the final drilling

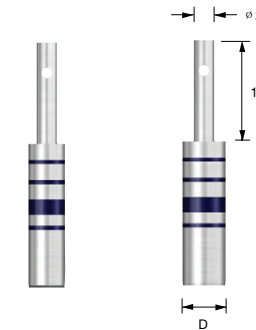

## Depth Gauge Pin for USII RBM

Length(mm)	Code
7	ADP607
8.5	ADP608
10	ADP610
11.5	ADP611
13	ADP613
15	ADP615
Full Set	ADP600

- Packing Unit : Individual and general set packing
- It is enable to check the drilling depth easily due to convenient design of top part

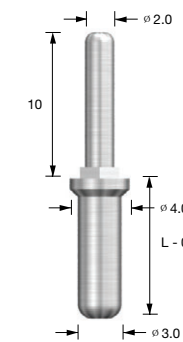

## Positioning Guide

Width(mm)	Code
2.5	APG201
6	APG202
11	APG203

- Packing Unit : Individual and general set packing
- Indicates the distance between fixtures
- Use after the first drilling (2.0)

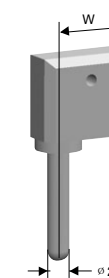

# Surgical Instruments for OSSTEM IMPLANT

## Tissue Height Gauge for TS



Code	GTHGS
------	-------

- Packing Unit: each part
- Measurement gingival height for selecting optimal abutment
- Non gloss treatment for improving identification

## Torque Wrench: Bar type



Code	TW30B
------	-------

- Packing Unit: each part
- Possibility of loading 10, 20, 30 and infinite Ncm
- Used to adjust the installation location of implants or to tighten abutments or screws
- The last line is approx. 40 Ncm
- Torque is applied to the center of the bar, which will be generated by pulling the bar
- The product should be cleaned after use, and then sterilized for storage

## Ratchet Wrench



Code	CITQW-1185A
------	-------------

- Packing Unit: each part
- Only surgical unlimited wrench (If excessive torque is applied, the inside of bone or fixture may be damaged.)
- Rotating direction is marked by an arrow for convenient identification

## NoMount Driver for TS

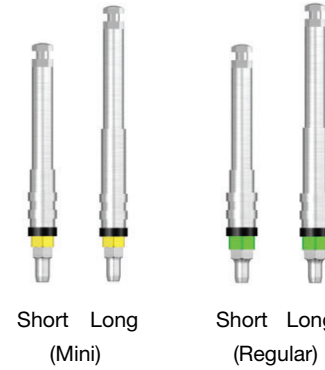

Type	Mini	Regular
Short	GSNMD32S	GSNMD35S
Long	GSNMD32L	GSNMD35L

- Packing Unit: each part
- To enable the simultaneous measurement of gingival height upon treatment, grooves and laser markings are indicated at 1-mm (1-6 mm) intervals
- Stopper designed for the prevention of fracture of the holding part and occurrence of foreign matter such as blood stain during the surgery

## NoMount Driver for SS

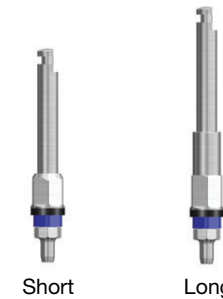

Type	Regular	Wide
Short	SSNOMD39RS	
Long	SSNOMD39RL	

- Packing Unit: each part
- Since the shape is similar to that of the internal fixture driver, even a high torque does not change the inside of the fixture
- Stopper designed for the prevention of fracture of the holding part and occurrence of foreign matter such as blood stain during surgery

## NoMount Driver for US

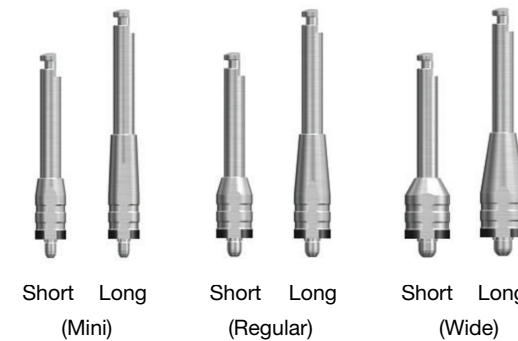

Length	Type	Mini	Regular	Wide
Short		USNMD35MS	USNMD41RS	USNMD51WS
Long		USNMD35ML	USNMD41RL	USNMD51WL

- Packing Unit: each part
- To enable the simultaneous measurement of gingival height upon treatment, grooves and laser markings are indicated at 1-mm (1-5 mm) intervals
- Stopper designed for the prevention of fracture of the holding part and occurrence of foreign matter such as blood stain during the surgery

# Surgical Instruments for OSSTEM IMPLANT

## NoMount Torque Driver for TS

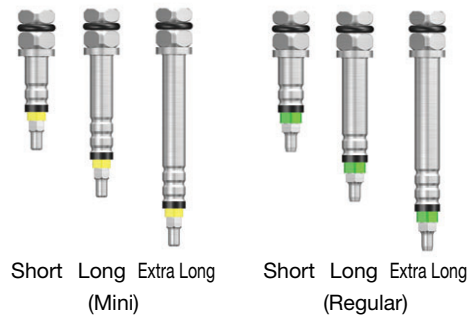

Type	Mini	Regular
Short	GSNMT32S	GSNMT35S
Long	GSNMT32L	GSNMT35L
Extra Long	GSNMT32E	GSNMT35E

- Packing Unit: each part
- To enable the simultaneous measurement of gingival height upon treatment, grooves and laser markings are indicated at 1mm intervals
- Stopper designed for the prevention of fracture of the holding part and occurrence of foreign matter such as blood stain during surgery
- The fracture strength : 260Ncm
- If excessive implant torque is applied, fracture may be resulted in; if unnecessary large implant torque is expected, use a fixture driver. Also, imperfect installation may result in fracture at the strength under fracture strength; therefore, perfect installation should be checked before use
- Special attention should be paid; after occurrence of a fracture, restoration is impossible

## NoMount Torque Driver for SS

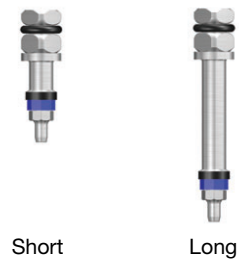

Type	Regular	Wide
Short	SSNMT39S	
Long	SSNMT39L	

- Packing Unit: each part
- Since the shape is similar to that of the internal fixture driver, even a high torque does not change the inside of the fixture
- Stopper designed for the prevention of fracture of the holding part and occurrence of foreign matter such as blood stain during surgery
- The fracture strength : 260Ncm
- If excessive implant torque is applied, fracture may be resulted in; if unnecessary large implant torque is expected, use a fixture driver. Also, imperfect installation may result in fracture at the strength under fracture strength; therefore, perfect installation should be checked before use.
- Special attention should be paid; after occurrence of a fracture, restoration is impossible.

## Fixture Driver for TS

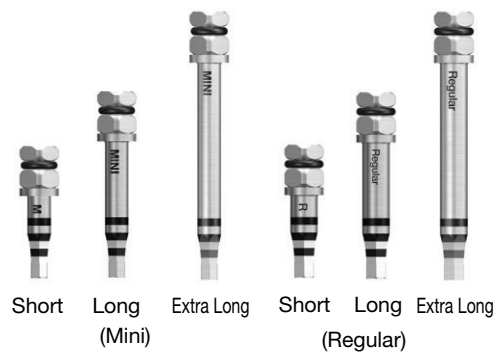

Type	Mini	Regular
Short	GSMFDS	GSRFDS
Long	GSMFDL	GSRFDL
Extra Long	GSMFDE	GSRFDE

- Packing Unit: each part
- Fixture connection
- Use to place or remove a fixture after the separation of the mount

## Fixture Driver for SS

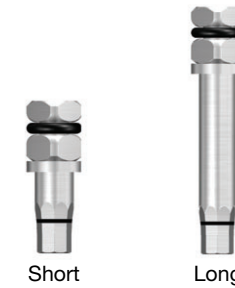

Platform(φ)	Regular	Wide
Short	SSRFDS	
Long	SSRFDL	

- Packing Unit: each part
- The laser marking is designed for checking during the connection of a fixture
- Use for removal following fixture grafting and mount separation

## Fixture Driver for US

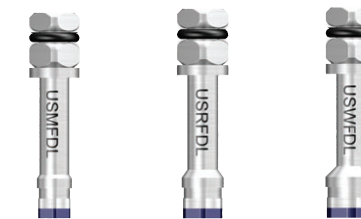

Platform(φ)	Mini	Regular	Wide
Code	USMFDL	USRFDL	USWFDL

- Packing Unit: each part
- The laser marking is designed for easy identification during the connection of fixtures
- Use for removal following fixture grafting and mount separation

## Simple Mount Driver

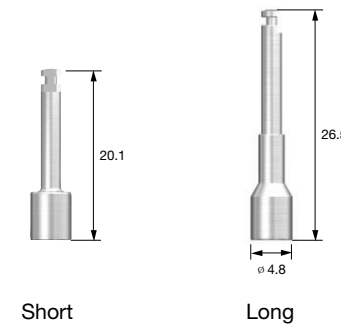

Length	Code
Short	ASMDS
Long	ASMDL

- Packing Unit: each part
- Use for fixture grafting by connecting to a simple mount
- Compact design, internal holding function

# Surgical Instruments for OSSTEM IMPLANT

## Simple Mount Extension

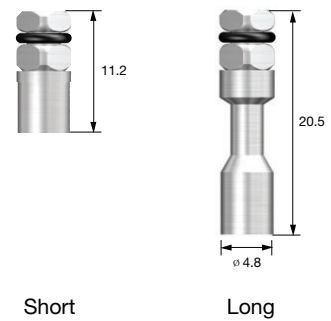

Length	Code
Short	ASMES
Long	ASMEL

- Packing Unit: each part
- Use for extension of simple mount length, and use in case of inputting hand-torque by connecting with ratchet wrench.

## Simple Open Wrench



Code	ASOW

- Packing Unit: each part
- For weak bone, use to separate the simple mount
- 30° neck angle enhances convenience of insertion in the oral cavity

## Removal Tool for Fixture Mount



Code	Application
ERFM	US Mini, TS Mini
HRFR	US Regular, SS Regular/Wide, TS Regular
ERFW	US Wide

- Packing Unit: each part
- When a fixture and the fixture mount are stuck, use after removing the fixture mount screw
- Use after the connection to a driver handle and a torque wrench
- Insert vertically and rotate clockwise

## Tissue Punch



Tissue Punch	A	φ 3.3	φ 3.8	φ 4.3	φ 4.8	φ 5.3
	Code	OSTP33	OSTP38	OSTP43	OSTP48	OSTP53
Application	TS	φ 4.0/ φ 4.5	φ 4.5/ φ 5.0	φ 5.0	φ 6.0	φ 6.0
Healing Abutment	SS	-	φ 4.8	-	φ 6.0	φ 6.0
Standard	US	φ 4.0	φ 5.0	φ 5.0	φ 6.0	φ 6.0

It is recommended to use the tissue punch that has the diameter smaller than that of healing abutment by 0.7~1.5mm.

- Packing Unit: Tissue Punch + Guide Pin
- Tool to be used for flapless surgery
- The laser marking at 2-mm intervals enables the measurement of gingival height

## TS Bone Profiler

Connection	Healing abutment dia.	Bone Profiler type		Guide Screw	
		Image	Code	Image	Code
Mini & Regular	φ 4.5		GSBP45	Mini Connection	
	φ 5.5		GSBP55		
	φ 6.5		GSBP75	Regular Connection	
	φ 7.5				

- Packing Unit : Bone Profiler + Guide Screw
- Use to remove the bone around the fixture during the first or second surgery
- It is used for compensation of the shape of healing abutment by eliminating the bone after connection of guide screw with the fixture
- The guide screw protects the morse taper of the fixtures



# Surgical Instruments for OSSTEM IMPLANT

## US Bone Profiler

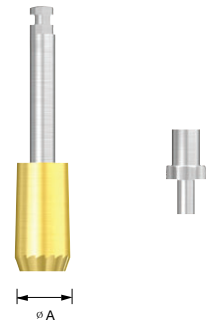

ø A	Platform(ø)			
	Mini	Regular	Wide	T-type
4	ABPM400C	-	-	-
5	ABPM500C	ABPR500C	-	-
6	-	ABPR600C	ABPW600C	TBPW600C
7	-	-	ABPW700C	-

- Packing Unit : Bone Profiler + Guide Screw
- Use to remove the bone generated around the cover screws during the second surgery
- After removing the cover screws, connect the guide screw to the fixtures and use for the angle compensation of the healing abutments
- The guide screw protects the hex of the fixtures
- TiN coating improves anti-corrosion and wear resistance

## Trepine Drill

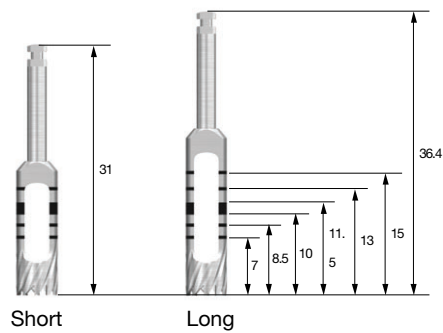

Code	Inner Dia.(ø)	Outer Dia.(ø)	Length
TD37S	3.7	4.5	Short
TD42S	4.2	5.0	Short
TD47S	4.7	5.5	Short
TD52S	5.2	6.0	Short
TD62S	6.2	7.0	Short
TD37	3.7	4.5	Long
TD42	4.2	5.0	Long
TD47	4.7	5.5	Long
TD52	5.2	6.0	Long
TD62	6.2	7.0	Long

- Packing Unit: each part
- Use for the collection of bone or removal of damaged or failed fixtures
- Use for removal of Septal bone
- Trepine drill can be used as initial drill when to implant Ultra Fixture

## Bone Mill

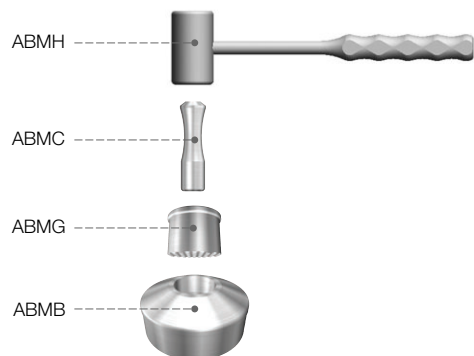

Code	ABM

- Packing Unit: each part
- Forms particulate bone using the collected autogenous bone

# Prosthetic KIT (OPK)

Use range (Use ■)

USII	SSII	TSII	Ultra-wide	MS	OS
USIII	SSIII	TSIII			

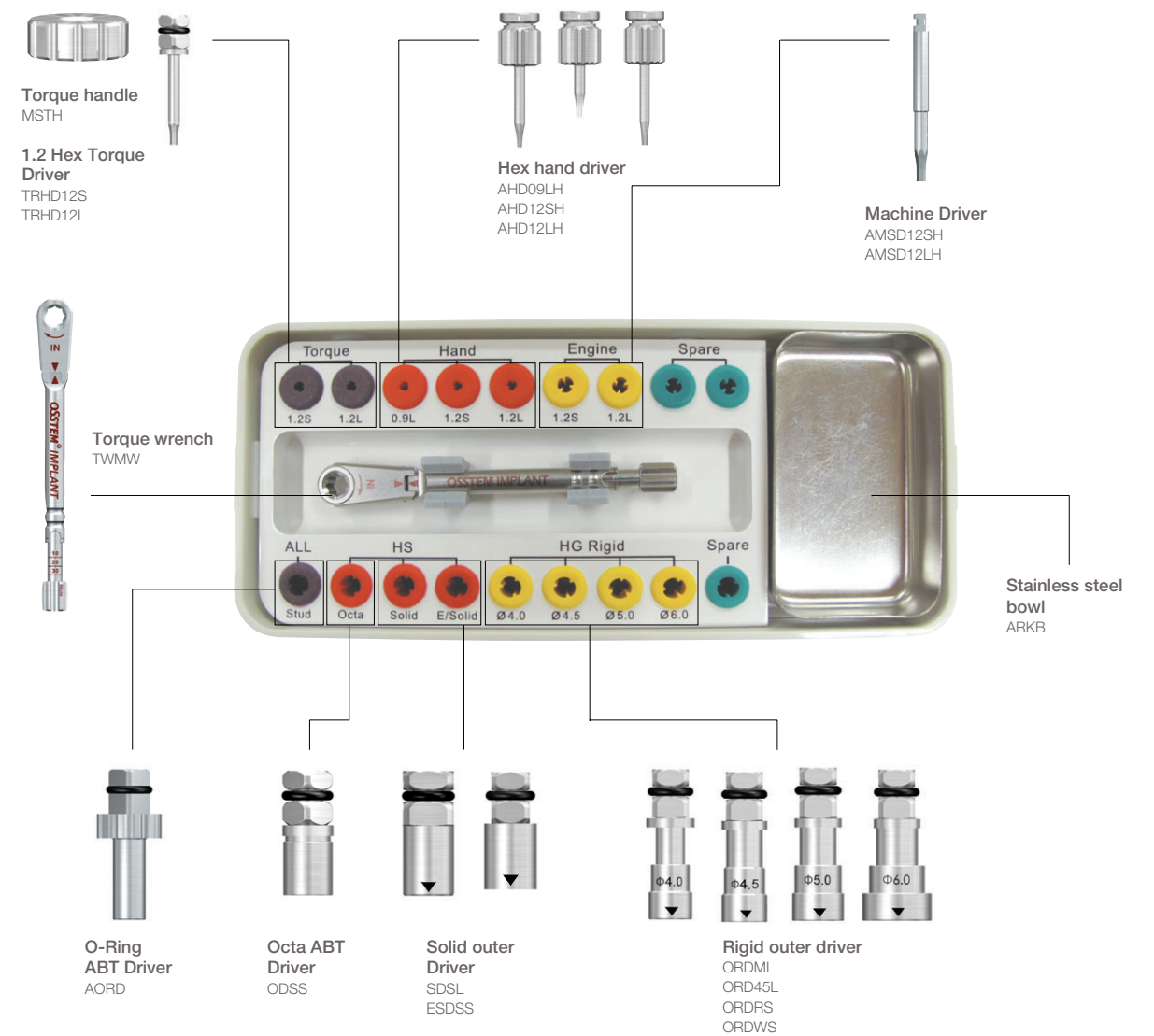

# TS Prosthetic KIT (GSPK)

Use range (Use  )

USII	SSII	TSII	Ultra-wide	MS	OS
USIII	SSIII	TSIII			

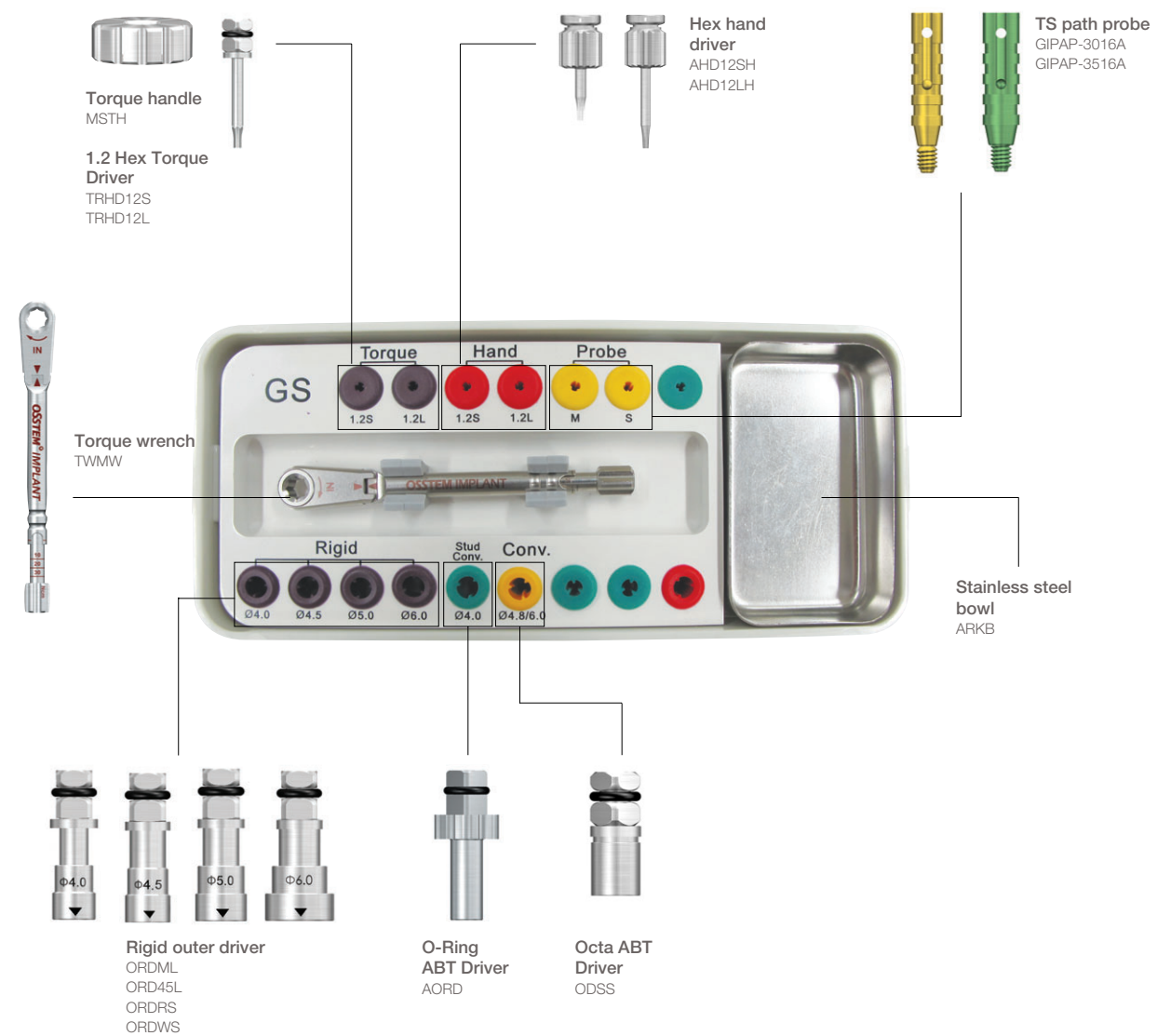

# Prosthetic Tools for OSSTEM IMPLANT

## Hand Driver

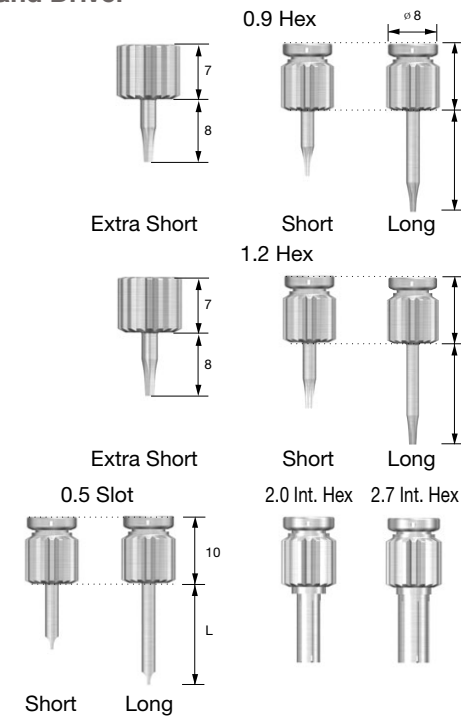

Type	Extra Short	Short	Long	Application
L	8	10.3	15.5	-
0.5Slot	-	ASD05SH	ASD05LH	-
0.9Hex	AHD09MSH	AHD09SH	AHD09LH	Cover Screw (US Mini)
1.2Hex	AHD12MSH	AHD12SH	AHD12LH	Healing Abutment, UCLA, Cemented Abutment Screw, Mount Screw
2.0 Int. Hex	-	IHD20H		Esthetic Abutment Screw Regular Esthetic-low Abutment Screw, Standard
2.7 Int. Hex	-	IHD27H		Wide Esthetic-low Abutment Screw

- Packing Unit: each part
- Manual driver
- Tip holding function (note: excluding Int. Hex Type)
- Int. Hex L is 11

## Machine Screw Driver

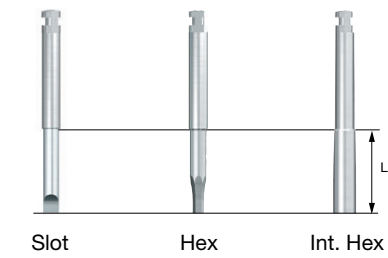

Type	Short	Long	Extra Long	Application
L(Slot)	7	11	-	-
L(Hex)	5	9	15	-
0.5Slot	AMSD05S	AMSD05L		-
0.9Hex	AMSD09S	AMSD09L		Cover Screw (US Mini)
1.2Hex	AMSD12S	AMSD12L	AMSD12E	Healing Abutment, UCLA, Cemented Abutment Screw, Mount Screw
2.0Int. Hex	EIHD20			Esthetic Abutment Screw Regular Esthetic-low Abutment Screw, Standard
2.7Int. Hex	EIHD27			Wide Esthetic-low Abutment Screw

- Packing Unit: each part
- Machine screw driver
- Tip holding function (note: excluding Int. Hex Type)
- Int. Hex L is 8

# Prosthetic Tools for OSSTEM IMPLANT

## Torque Driver

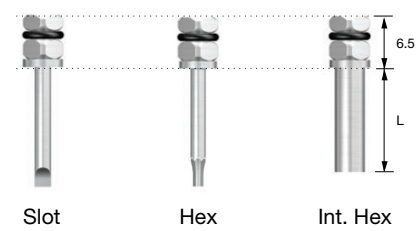

Type	Short	Long	Extra Long	Application
L	9.5	15	25	-
0.5Slot	TRSD05S	TRSD05L	TRSD05E	-
0.9Hex	TRHD09S	TRHD09L	-	Cover Screw(US Mini)
1.2Hex	TRHD12S	TRHD12L	TRHD12E	Healing Abutment, UCLA,Cemented Abutment Screw, Mount Screw
2.0Int. Hex	TIHD20S	TIHD20L	-	Standard/ Esthetic Abutment Screw, Regular Esthetic-low Abutment Screw
2.7Int. Hex		TIHD27		Wide Esthetic-low Abutment Screw

- Packing Unit: each part
- Driver for torque wrench connection
- No tip holding function
- Fracture strength: 62Ncm
- Recommended torque should be observed.  
Caution: Fracture occurs, in case excessive torque is applied.
- When applying torque, check that the screw hex is completely installed.  
Application of torque with imperfect installation may result in a fracture at the strength under fracture strength.
- Torque should be applied vertically. (Do not tilt the set.)
- If the tip is bent due to the use for a long time or excessive torque, replace it.

## O-ring Abutment Driver

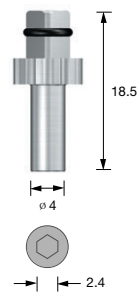

Code	AORD
------	------

- Packing Unit: each part
- Special-purpose driver for the O-ring abutment

## Rigid Outer Driver



Spec.	Mini	Regular			
Abutment D(φ)	φ 4.0	φ 4.0	φ 4.5	φ 5.0	φ 6.0
Short	ORDMS	ORD45S	ORDRS	ORDWS	
Long	ORDML	ORD45L	ORDRL	ORDWL	

- Packing Unit: each part
- Special-purpose driver for rigid abutment
- Tightening torque : 30Ncm

## Solid Abutment Driver



Platform (φ)		Regular		Wide	
Length	Type	Square	Round	Square	Round
Short		SDSS	SDRS	SD60S	-
Long		SDSL	SDRL	-	-

- Packing Unit: each part
- Driver for Solid abutment
- The triangle mark is used by aligning with the abutment groove
- Tightening torque : 30Ncm

## Excellent Solid Abutment Driver

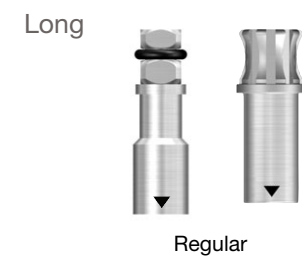
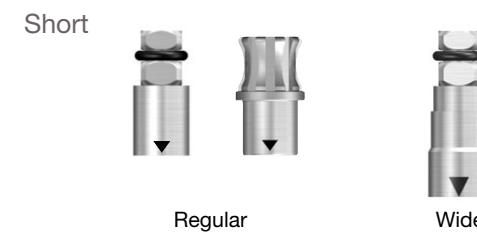

Platform (φ)		Regular		Wide	
Length	Type	Square	Round	Square	Round
Short		ESDSS	ESDRS	ESD60S	-
Long		ESDSL	ESDRL	-	-

- Packing Unit: each part
- Driver for Excellent solid abutment
- The triangle mark is used by aligning with the abutment groove
- Tightening torque : 30Ncm

## Octa Abutment Driver



Length	Type	Square	Round
Short		ODSS	ODRS
Long		ODSL	ODRL

- Packing Unit: each part
- Driver for Octa abutment
- Tightening torque : 30Ncm

# Prosthetic Tools for OSSTEM IMPLANT

## OSSTEM Torque Driver

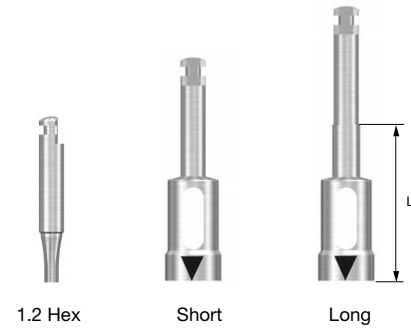

Type	Short	Long
L	10	15
1.2 Hex	OTH12S	-
Rigid ø 4.0	OTR40S	OTR40L
Rigid ø 4.5	OTR45S	OTR45L
Rigid ø 5.0	OTR50S	OTR50L
Rigid ø 6.0	OTR60S	OTR60L
Solid	OTS48S	OTS48L
Excellent Solid	OTE48S	OTE48L

- Packing Unit: each part
- Driver for OSSTEM Torque
- The triangle mark is used by aligning with the abutment groove of section
- Tightening torque : 30Ncm(except 1.2 Hex Type)
- Solid and Excellent Solid Driver are compatible with ? 4.8 exclusively.
- Impossibility of connection with general hand piece
- 1.2Hex L(Tip length) is 5.

## Path Probe for GS, TS

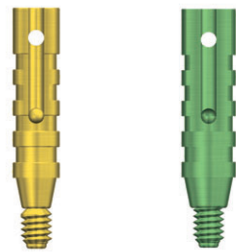

	Mini	Regular
Short	GIPAP-3016A	GIPAP-3516A

- Packing Unit: each part
- After GS,TS NoMount driver, confirmation path and measurement gingival height
- For mini : **Yellow**
- For Regular : **Green**

## Connector



Code	ORC

- Packing Unit: each part
- Connector used for connecting the driver for square torque to the round torque wrench

## Driver Handle

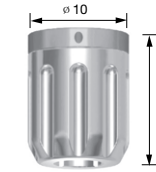

Code	TIDHC

- Packing Unit: each part
- Use by connecting with a torque driver

## Dalbo Plus Screw Driver



Code	ODSD

- Packing Unit: each part
- Use to adjust the retention force of Dalbo plus Attachment

## Finishing Reamer Set



Code	FRSC

- Packing Unit: each part
- Use to remove the lip inside the casting body upon the casting of plastic copings

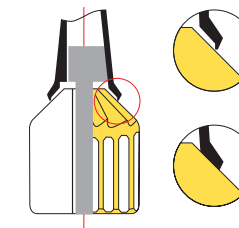

- \* How to use reamer
- Choose a reamer tip as same size as abutment and then connect the casting burm-out Cylinder.
  - Hold the casting body and rotate reamer bite with consistent force
  - Do reaming until cutting does not occur any longer

# Prosthetic Tools for OSSTEM IMPLANT

## Reamer Bite



Code	FRBC
------	------

- Packing Unit: each part
- TiN coating improves anti-corrosion and wear resistance

## Reamer Tip for Rigid Abutment

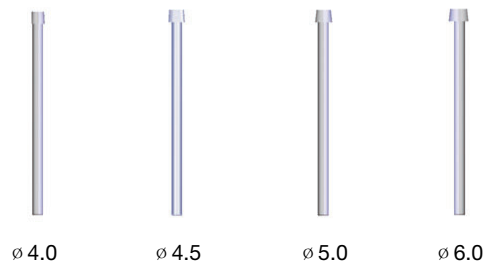

Abutment D (φ)	φ 4.0	φ 4.5	φ 5.0	φ 6.0
Code	GSRFRT400	GSRFRT450	GSRFRT500	GSRFRT600

- Packing Unit: each part
- When fabricating the prosthesis using a Rigid plastic coping, it is used for margin contact adjustment.

## Reamer Tip for Solid, Ex. Solid Abutment

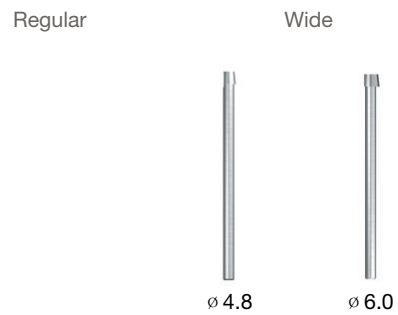

Abutment D (φ)	φ 4.8	φ 6.0
Solid	FRTS480	FRTS600
Excellent Solid	FRTE480	FRTE600

- Packing Unit: each part
- Combined use of Solid φ 6.0 and Excellent Solid φ 4.8

# CAS-KIT (HCRSNK)

Use range (Use  )

USII	SSII	TSII	Ultra-wide	MS	OS
USIII	SSIII	TSIII			

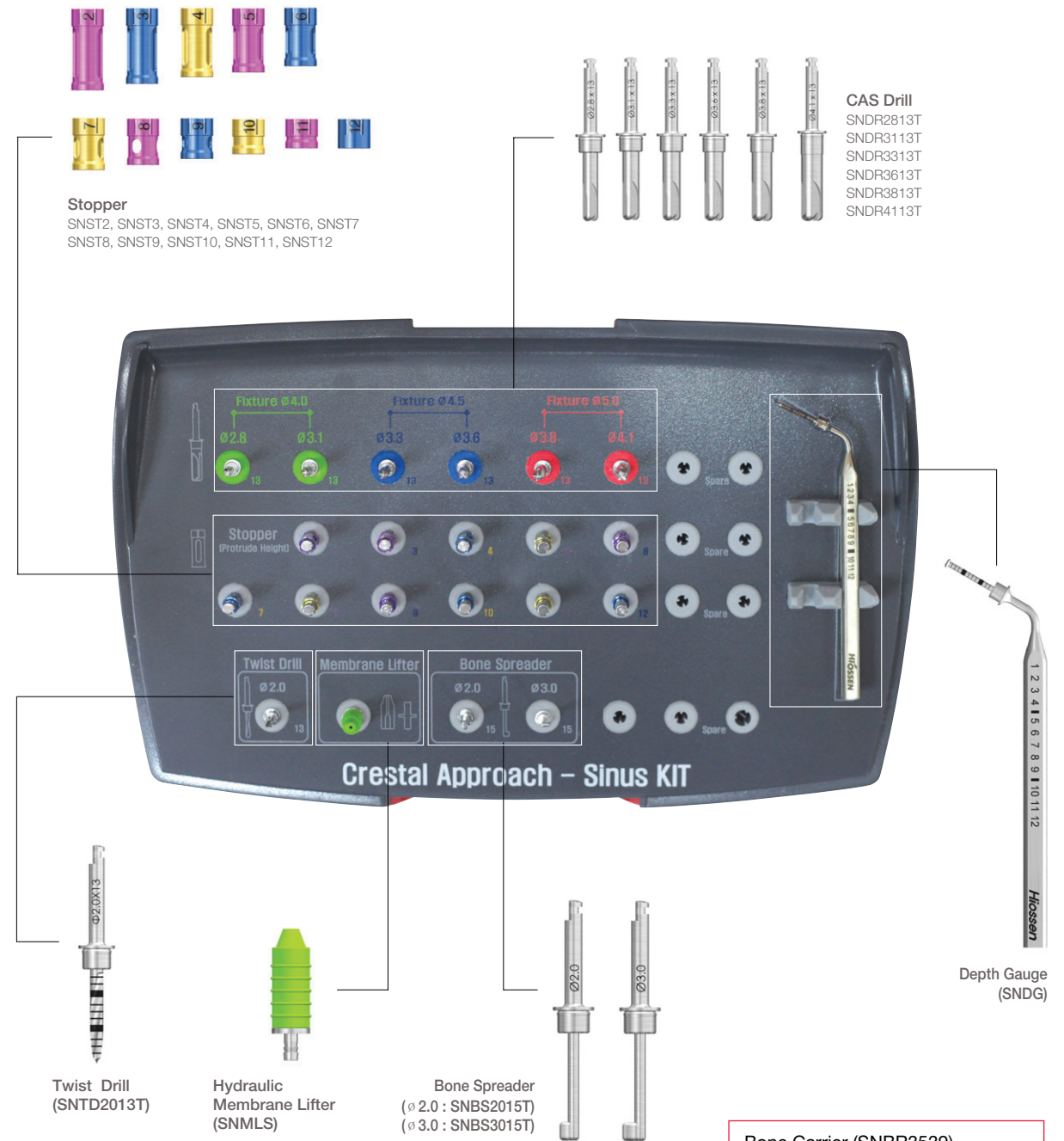

- This surgical procedure use only Maxillary sinus surgery. Don't use for Mandible surgery.
- The CAS-KIT has a one year warranty on all parts & case.
- The recommended usage of the drills and stopper are 50 times.
- For more information, Please visit [www.hiossen.com](http://www.hiossen.com) or see the Surgical Animation or Brochure.

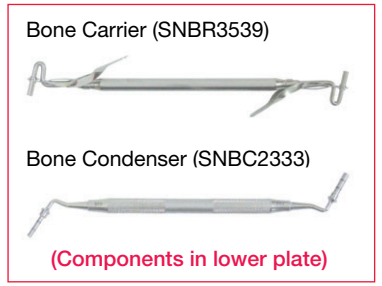

(Components in lower plate)

# CAS Surgical Instruments for OSSTEM IMPLANT

## CAS-Drill

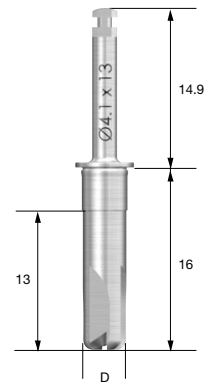

Fixture $\phi$	F $\phi$ 4.0		F $\phi$ 4.5		F $\phi$ 5.0	
Bone Density	Soft	Normal	Soft	Normal	Soft	Normal
D	$\phi$ 2.8	$\phi$ 3.1	$\phi$ 3.3	$\phi$ 3.6	$\phi$ 3.8	$\phi$ 4.1
Code	SNDR2813T	SNDR3113T	SNDR3313T	SNDR3613T	SNDR3813T	SNDR4113T

- Package unit : each part
- Make a conical bone lid for membrane safely lifting.
- Flexible Drilling speed ranges from low speed to high speed (800rpm) Especially, Bone harvesting in low speed (about 50rpm)
- Drill depth control by unique stopper systems.

## $\phi$ 2.0 Twist Drill

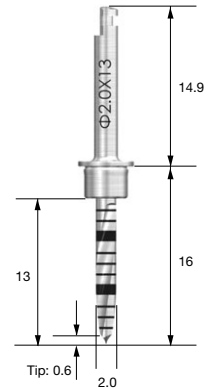

Code	SNTD2013T
------	-----------

- Package unit : each part
- Under drilling than 2mm of remaining bone in CT or panorama
- Tip : 0.6mm
- Drill depth control by unique stopper systems.

## Stopper



Remaining Length(mm)	2	3	4	5	6	7	8	9	10	11	12
Code	SNST2	SNST3	SNST4	SNST5	SNST6	SNST7	SNST8	SNST9	SNST10	SNST11	SNST12

- Package unit : each part
- A total of eleven (11) stoppers; labeled 2 to 12mm
- Labels indicate the remaining length of the drill (from drill tip to stopper top)
- Each stopper is anodized and color coded. Labels are laser etched.

## Drilling Sequence



- This surgical procedure use only Maxillary sinus surgery. Don't use for Mandible surgery.
- For more information, can visit [www.hiossen.com](http://www.hiossen.com)

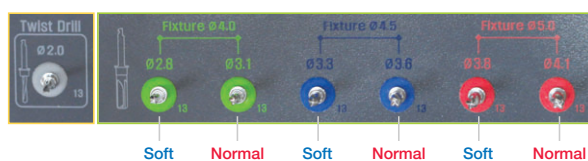

Fixture Selection	Twist Drill	CAS-Drill						
F(D $\phi$ )	Bone Density	$\phi$ 2.0	$\phi$ 2.8	$\phi$ 3.1	$\phi$ 3.3	$\phi$ 3.6	$\phi$ 3.8	$\phi$ 4.1
$\phi$ 4.0	Soft	▶	▶					
		▶	▶					
		▶	▶					
$\phi$ 4.5	Soft	▶	▶					
		▶	▶					
		▶	▶					
$\phi$ 5.0	Soft	▶	▶					
		▶	▶					
		▶	▶					
$\phi$ 4.0	Normal	▶		▶				
		▶		▶				
		▶		▶				
$\phi$ 4.5	Normal	▶		▶				
		▶		▶				
		▶		▶				
$\phi$ 5.0	Normal	▶		▶				
		▶		▶				
		▶		▶				

# LAS-KIT (HLRSNK)

- Dome drill  $\phi$  5.5/ $\phi$  7.0 & Wide dome drill  $\phi$  7.0, Core drill  $\phi$  5.5/ $\phi$  7.0, Side wall drill, Bone separator, Stopper 0.5 / 1.0 / 1.5 / 2.0 / 2.5 / 3.0

\* Sinus Kit sold separately.

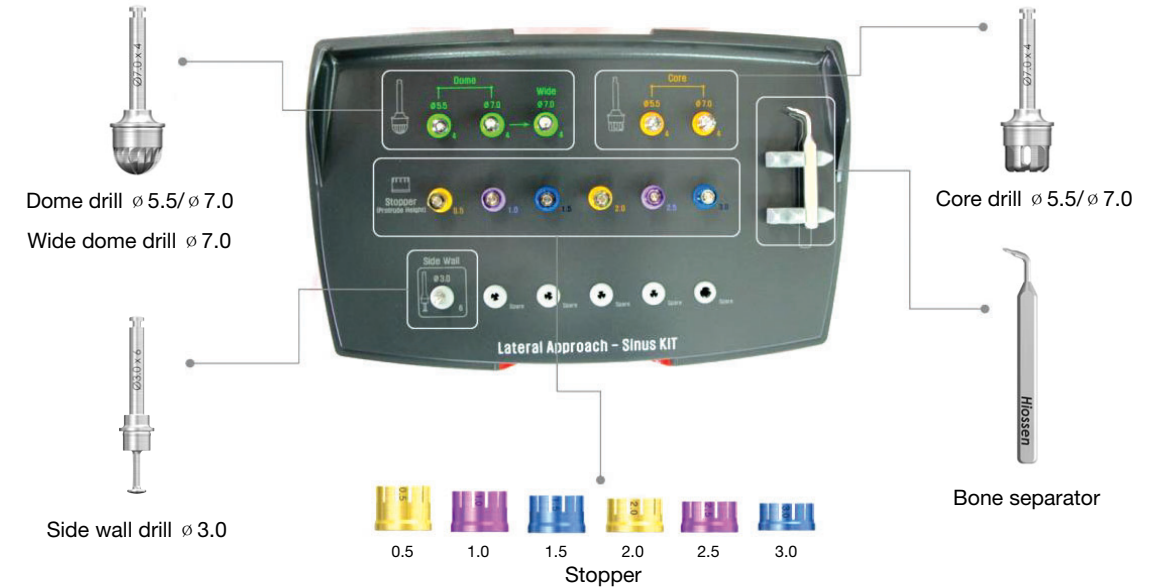

# LAS Surgical Instruments for OSSTEM IMPLANT

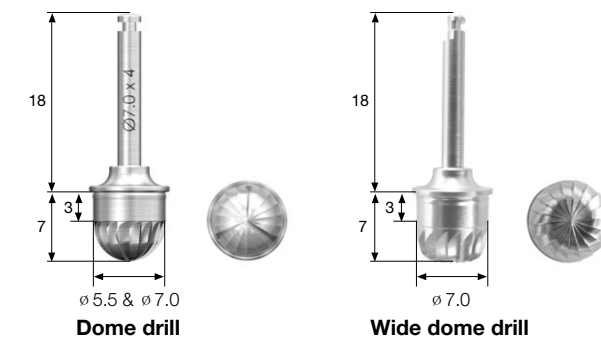

- **Dome Drill**
  - Macro and Micro cutting blades offer excellent cutting
  - Cutting Speed: 1,200 ~ 1,500 RPM
  - Drilling depth controlled with stopper system
- **Wide dome drill**
  - Used to widen the window after using Dome drill
  - Excellent side cutting ability
  - Drilling depth controlled with stopper system
  - Cutting Speed: 1,200 ~ 1,500 RPM
  - \* Caution: Over drilling may cause membrane perforation.

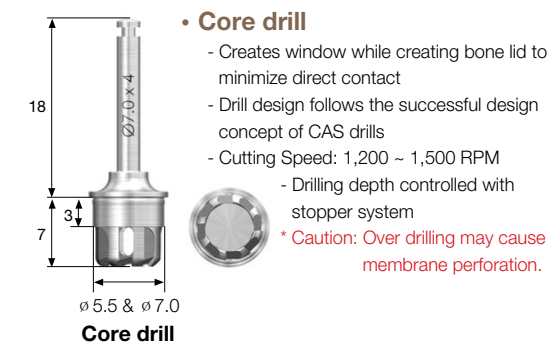

- **Core drill**
  - Creates window while creating bone lid to minimize direct contact
  - Drill design follows the successful design concept of CAS drills
  - Cutting Speed: 1,200 ~ 1,500 RPM
  - Drilling depth controlled with stopper system
  - \* Caution: Over drilling may cause membrane perforation.

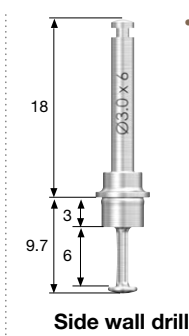

- **Side wall drill**
  - Enlarges the window after using Dome drill
  - Cutting Speed: 1,500 RPM
  - Recommended to use cutting edge 1mm from the bottom.

CAS-KIT Stopper(mm)	Side wall drill length (H:mm)	Side wall drill + CAS-KIT Stopper
12	5	
11	4	
10	3	
9	2	
8	1	

# LAS-KIT Plus (HLRSNKP)

- Dome drill  $\phi$  5.5/ $\phi$  7.0 & Wide dome drill  $\phi$  7.0, Core drill  $\phi$  5.5/ $\phi$  7.0, Side wall drill, Bone separator, Stopper 0.5 / 1.0 / 1.5 / 2.0 / 2.5 / 3.0

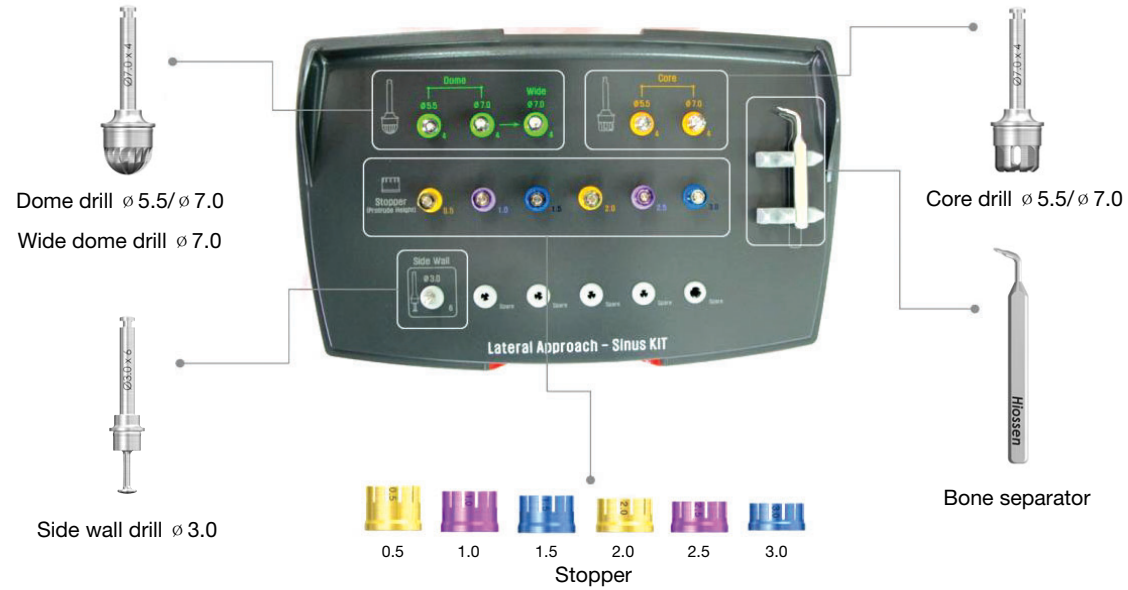

# LAS Surgical Instruments for OSSTEM IMPLANT

- LAS-KIT Plus have a 5 tools of sinus lift in lower plate.

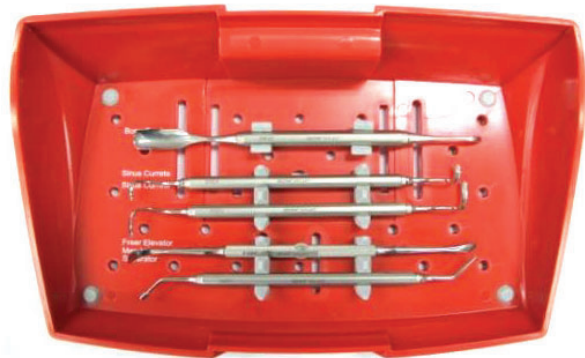

- ※ Composition of lower plate
- Freer Elevator : FREL
  - Bone Graft Carrier : BGCR
  - Membrane Separator : MBSP
  - Sinus Curette : Short - SNCRS
  - Sinus Curette : Long - SNCRL

Instrument	D.	Code
Dome drill	$\phi$ 5.5	LSDR554TD
	$\phi$ 7.0	LSDR74TD
Wide dome drill	$\phi$ 7.0	LSDR74WTD
Core drill	$\phi$ 5.5	LSDR554TC
	$\phi$ 7.0	LSDR74TC
Side wall Drill	-	SWDR36T
Bone Separator	-	HST75

Stopper	0.5	1.0	1.5	2.0	2.5	3.0
Code	LSNSH0.5	LSNST1.0	LSNST1.5	LSNST2.0	LSNST2.5	LSNST3.0

# MS KIT (OMSK)

Use range (Use ■)

USII	SSII	TSII	Ultra-wide	MS	OS
USIII	SSIII	TSIII			

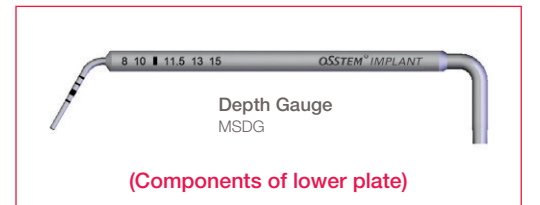
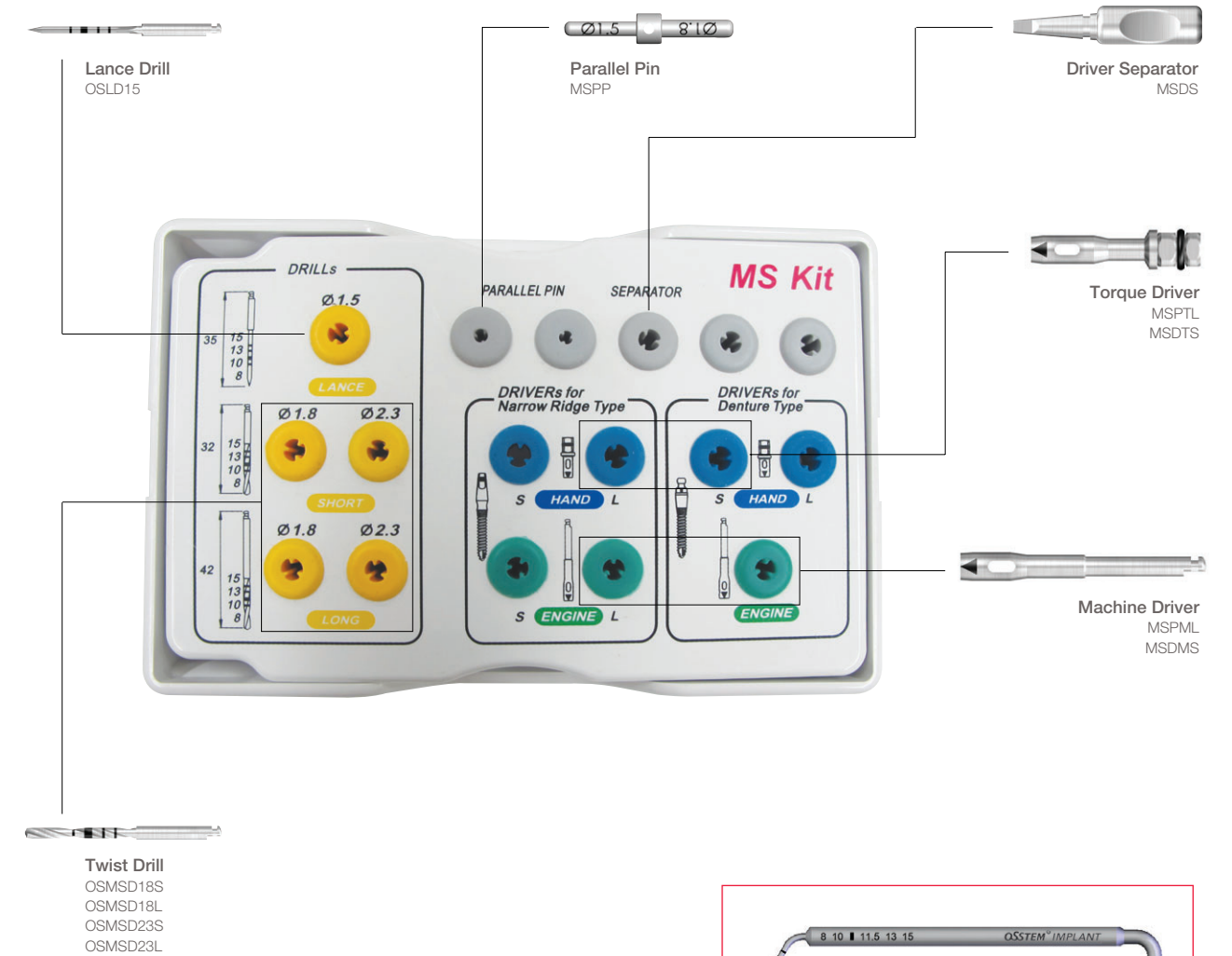

# Ortho KIT (OOKS)

Use range (Use  )

USII	SSII	TSII	Ultra-wide	MS	OS
USIII	SSIII	TSIII			

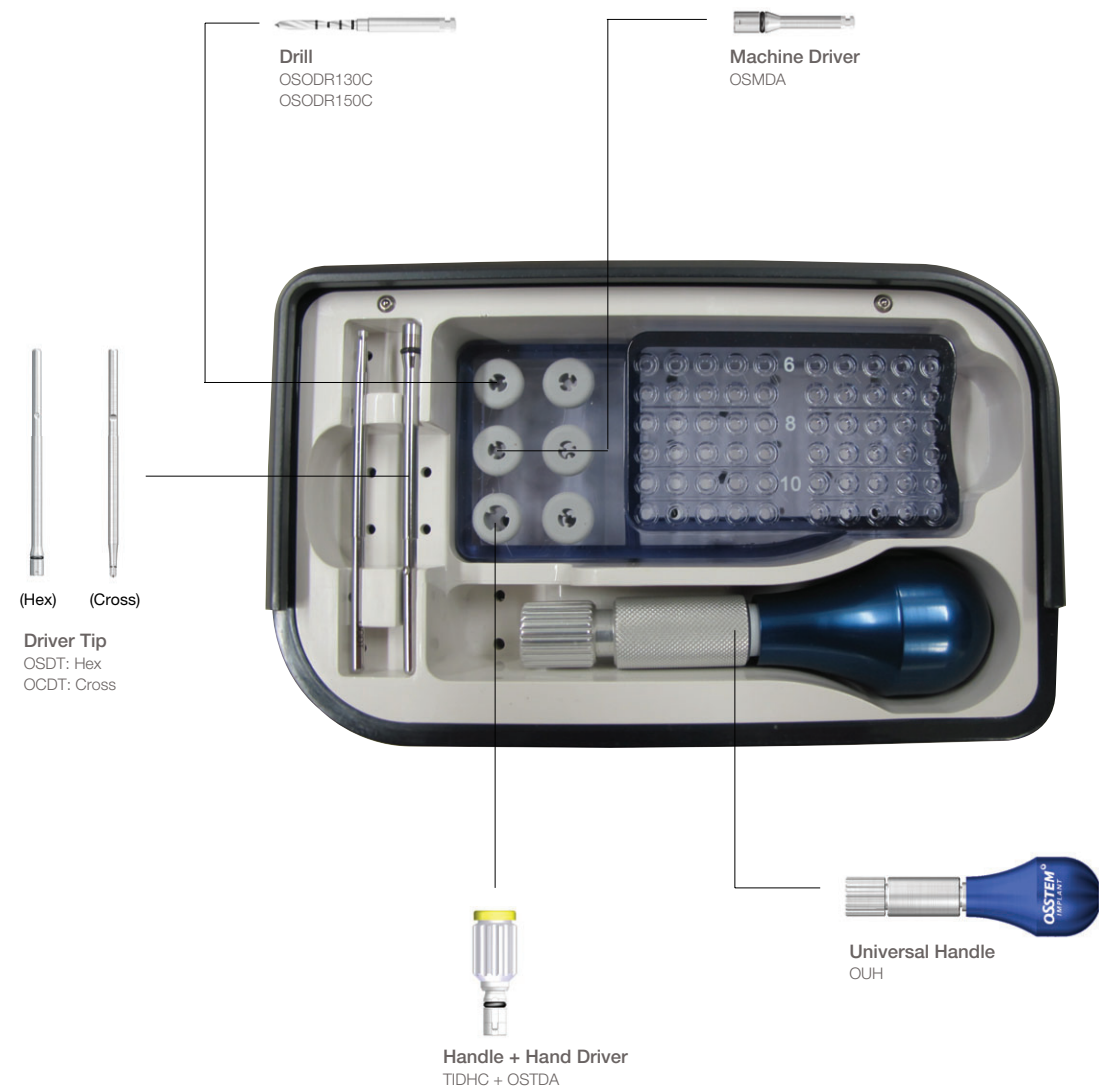

# Bone Screw KIT (BSSTKT)

Use range (Use  )

USII	SSII	TSII	Ultra-wide	MS	OS	BS
USIII	SSIII	TSIII				

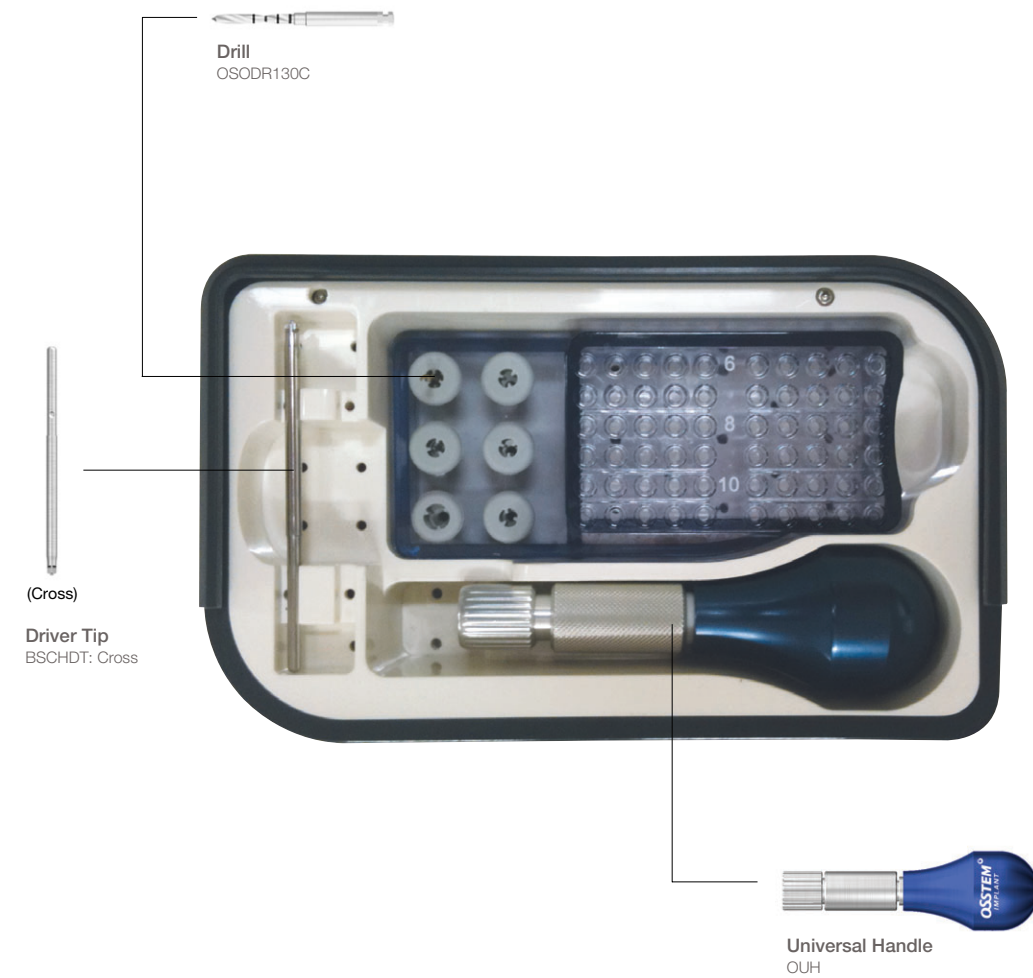



# Custom KIT(OCTK)

Use range (Use  )

USII	SSII	TSII	Ultra-wide	MS	OS
USIII	SSIII	TSIII			



## OCTK

- When only part in the surgical operation organization sterilization, uses.
- Composition of additional rubber (small, middle, large)
- Use for autoclave (132°C, 15min)

# Osteo KIT (OSTK)



## OSTK

- Concave Osteotome : Use for maxillary sinus elevation for the vertical expansion of the volume of alveolar bone available in the maxillary posterior
- Expanding Osteotome : Without cutting low-quality bone, the preservation of the bone densifies the bone trabeculato enhance the initial bonding of implants
- Stopper for the adjustment of surgical depth

Dia.	Concave type	Expanding type
ø 2.0mm	OST20CA	OST20EA
ø 2.5mm	OST25CA	OST25EA
ø 3.0mm	OST30CA	OST30EA
ø 3.5mm	OST35CA	OST35EA
ø 4.0mm	OST40CA	OST40EA
Mallet	OSTMP	

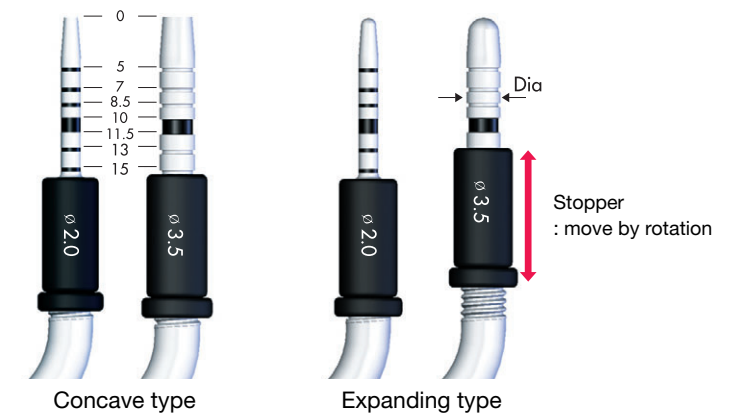

# Osteotome KIT (AOST)

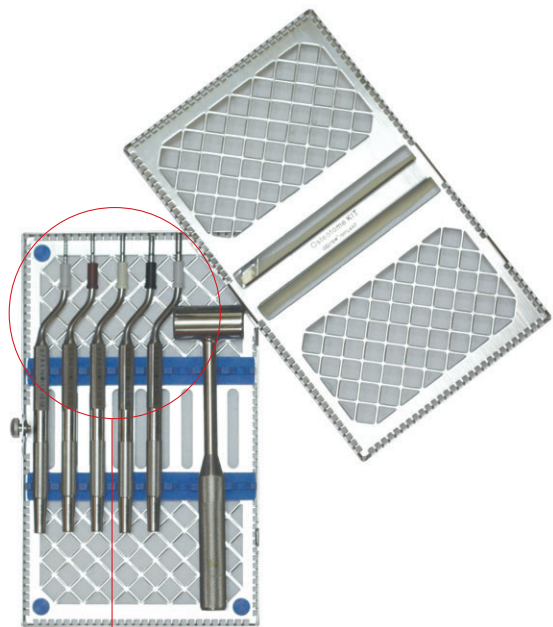

## AOST

- Use for maxillary sinus elevation for the vertical expansion of the volume of alveolar bone available in the maxillary posterior
- Includes only the concave type
- Stopper for the adjustment of surgical depth

Dia.	Concave type
ø 2.0mm	OST20CA
ø 2.5mm	OST25CA
ø 3.0mm	OST30CA
ø 3.5mm	OST35CA
ø 4.0mm	OST40CA
Mallet	OSTM



# Sinus KIT (ASLK)

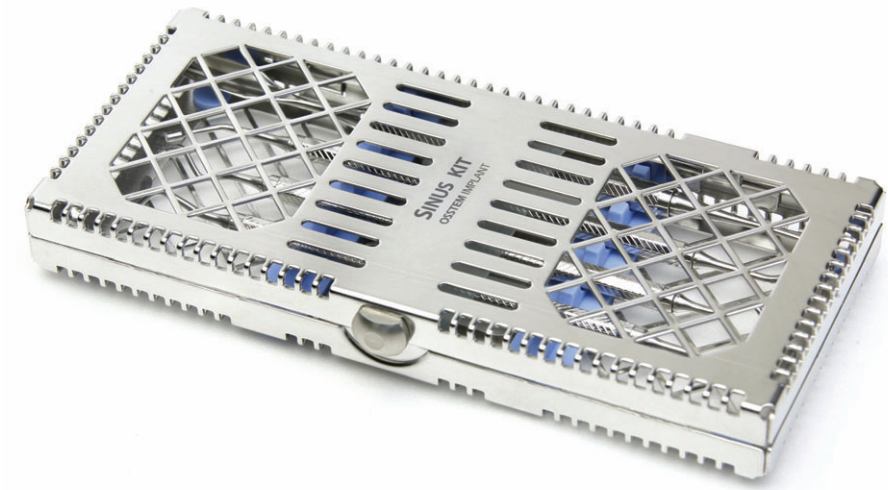

## ASLK

- Various types of tools (5) used for the sinus procedure
- Sinus operation instrument for lateral approach

### ※ 5 components

- Freer Elevator : OFE
- Bone Graft Carrier : OBGC
- Membrane Separator (Circle type) : OMSC
- Sinus Curette-Short : OSCS
- Sinus Curette-Long : OSCL

# Abutment Selector [TSASK]



## TSASK

- The kits to be selected before selecting an abutment.
- ※ Component
  - Rigid each 2ea. Total 28ea
  - Angled each 1ea. Total 6ea
- Caution : Kit case sterilization impossibility

# Bone Spreader KIT (OBSOK)

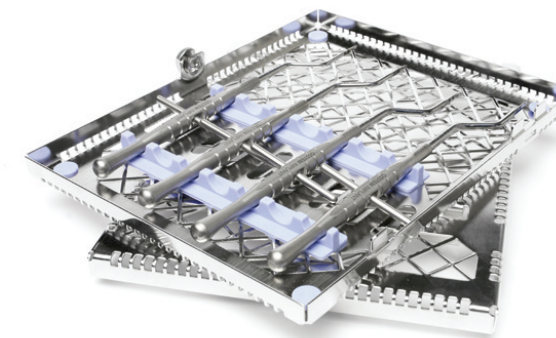

## OBSOK

- Use for alveolar bone expansion
- Offset type for easy operation
- ※ Components
  - OBSO22F, OBSO28F, OBSO35F, OBSO35R

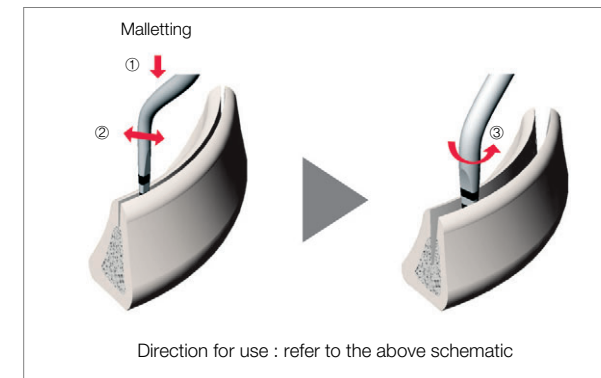

- Use for alveolar bone expansion
- Offset type for easy operation
- Depth marking corresponding to the implant length.

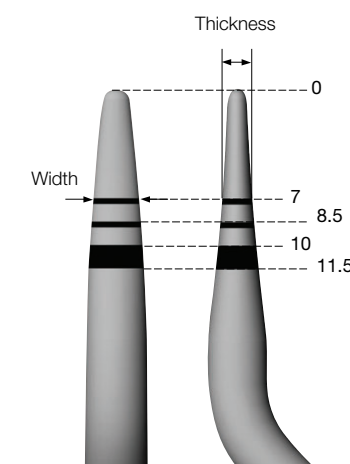

		(Unit : mm)			
Code	Spec.	Tip length			
		7	8.5	10	11.5
OBSO22F	Thickness	1.15	1.3	1.45	1.6
	Width	2.1	2.2	2.2	2.2
OBSO28F	Thickness	1.15	1.3	1.45	1.6
	Width	2.65	2.8	2.8	2.8
OBSO35F	Thickness	1.3	1.45	1.6	1.8
	Width	3.3	3.5	3.5	3.5
OBSO35R (Round Type)	Thickness	1.85	2.1	2.3	2.55
	Width	3.3	3.5	3.5	3.5

# Ridge Split KIT- Straight (ORSSK)



## ORSSK

### ※ Components

Ridge Split Chisel : ORSS15, ORSS20, ORSS25, ORSS30

Blade Holder : ORSBH

- Chisel : Use to expand narrow alveolar bone
- Use to malleting by connecting #15 Blade in case of difficult incision in soft bone

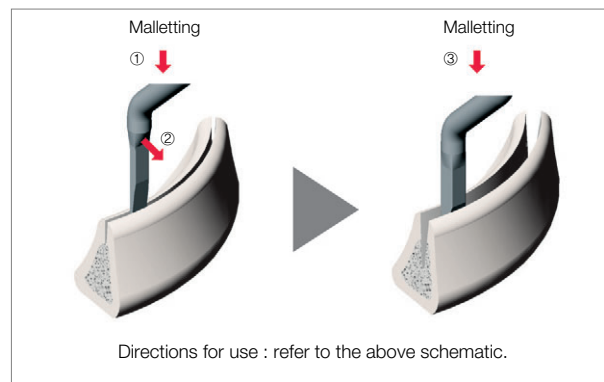
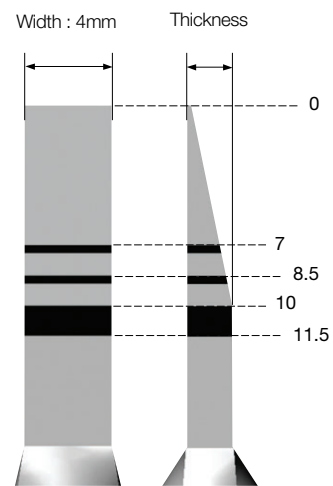

(Unit : mm)

Code	Spec.	Tip length			
		7	8.5	10	11.5
ORSS15	Thickness	1.1	1.27	1.5	1.5
	Width	4	4	4	4
ORSS20	Thickness	1.45	1.7	2.0	2.0
	Width	4	4	4	4
ORSS25	Thickness	1.8	2.15	2.5	2.5
	Width	4	4	4	4
ORSS30	Thickness	2.15	2.5	3.0	3.0
	Width	4	4	4	4

# Ridge Split KIT- Offset (ORSOK)



## ORSOK

### ※ Components

Ridge Split Chisel : ORSO15, ORSO20, ORSO25, ORSO30

Blade Holder : ORSBH

- Use for alveolar bone expansion
- Offset type for easy operation

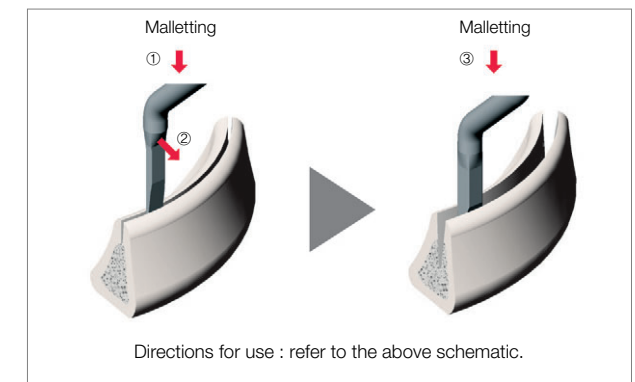
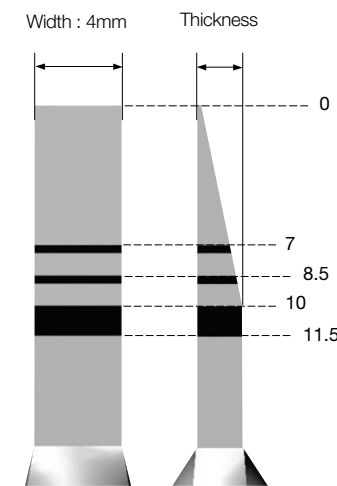

(Unit : mm)

Code	Spec.	Tip length			
		7	8.5	10	11.5
ORSO15	Thickness	1.1	1.27	1.5	1.5
	Width	4	4	4	4
ORSO20	Thickness	1.45	1.7	2.0	2.0
	Width	4	4	4	4
ORSO25	Thickness	1.8	2.15	2.5	2.5
	Width	4	4	4	4
ORSO30	Thickness	2.15	2.5	3.0	3.0
	Width	4	4	4	4

# OsstemGuide™ Surgical Components

## 1. Implant System

- The implants that can be used with OsstemGuide are the tapered type implant systems of Osstem and Hiossen.

▶ If length of 7 or 15mm fixture is to be used, you should purchase the exclusively designed drill.

## 2. Surgical Kit (Code : OGDK) components



- |   |   |  |   |   |
|---|---|--|---|---|
| <p><b>1</b> Anchor drill<br/>• QGATD13</p> <p><b>2</b> Anchor Screw<br/>• QGAS18</p> <p><b>3</b> Tissue punch<br/>• QGTP33M<br/>• QGTP38R<br/>• QGTP47R<br/>• QGTP53W</p> <p><b>4</b> Initial drill<br/>• QGID20M<br/>• QGID20R<br/>• QGID20W</p> | <p><b>5</b> Twist Drill<br/>• QGTD2008<br/>• QGTD2010<br/>• QGTD2011<br/>• QGTD2013</p> <p>• QGTD3008<br/>• QGTD3010<br/>• QGTD3011<br/>• QGTD3013</p> <p>• QGTD3308<br/>• QGTD3310<br/>• QGTD3311<br/>• QGTD3313</p> <p>• QGTD3808<br/>• QGTD3810<br/>• QGTD3811<br/>• QGTD3813</p> <p>• QGTD4308<br/>• QGTD4310<br/>• QGTD4311<br/>• QGTD4313</p> | <p><b>6</b> Cortical Drill 3<br/>• QGCD335M<br/>• QGCD340R<br/>• QGCD345R<br/>• QGCD350W</p> <p><b>7</b> Drill Guide<br/>• QGDG20M<br/>• QGDG30M<br/>• QGDG20R<br/>• QGDG30R<br/>• QGDG33R<br/>• QGDG38R<br/>• QGDG20W<br/>• QGDG30W<br/>• QGDG38W<br/>• QGDG43W</p> <p><b>8</b> 1.2 Hex hand driver<br/>• AHD12SH<br/>• AHD12LH</p> | <p><b>9</b> 1.2 Hex torque driver<br/>• TRHD12S<br/>• TRHD12L</p> <p><b>10</b> Mount Driver<br/>• ASMDS</p> <p><b>10</b> Mount Extension<br/>• ASMES</p> <p><b>11</b> Removal Tool<br/>• QGRTR</p> <p><b>11</b> USIII Countersink<br/>• OGUSCS45W</p> | <p><b>12</b> Kit Steel bowl<br/>• AKB</p> <p><b>13</b> Ratchet Wrench<br/>• CITQW-1185A</p> <p><b>14</b> Open Wrench<br/>• ASOW</p> |
|---|---|--|---|---|

# OsstemGuide™ Surgical Components

- The tools that are clinically needed in addition to the tools provided with the OsstemGuide KIT are shown in the list below.



L	D	ø 2.0	ø 3.0	ø 3.3	ø 3.6	ø 3.8	ø 4.1	ø 4.3	ø 4.6
		7	QGTD2007 *	QGTD3007 *	QGTD3307 *	QGTD3607 *	QGTD3807 *	QGTD4107 *	QGTD4307 *
8.5				QGTD3608 *		QGTD4108 *		QGTD4608 *	
10				QGTD3610 *		QGTD4110 *		QGTD4610 *	
11.5				QGTD3611 *		QGTD4111 *		QGTD4611 *	
13				QGTD3613 *		QGTD4113 *		QGTD4613 *	
15		QGTD2015 *	QGTD3015 *	QGTD3315 *	QGTD3615 *	QGTD3815 *	QGTD4115 *	QGTD4315 *	QGTD4615 *
Drill Guide					QGDG36R * (Regular)		QGDG41R * (Regular)		QGDG46W * (Wide)

The products marked with "\*" are not included in the kit and you should purchase them if needed.

## 3. Specific features of surgical drills

- All of the drills have the drill stops to meet OsstemGuide drill guides.
- Each drill has additional length of 10mm to meet the installation height of surgical template and drill guide.
- 8.5mm length drill is laser-marked at 7/8.5/10/11.5/13/15mm and can be used in common surgery without OsstemGuide.
- Especially, although the lateral side of the drill touches the gingival during flapless operation, the uniquely designed drill does not damage the soft tissue.
- The tip length of ø 2.0 drill is 0.6mm, ø 3.0 drill is 0.9mm, and ø 3.3 ~ ø 4.6 drill is 1mm.

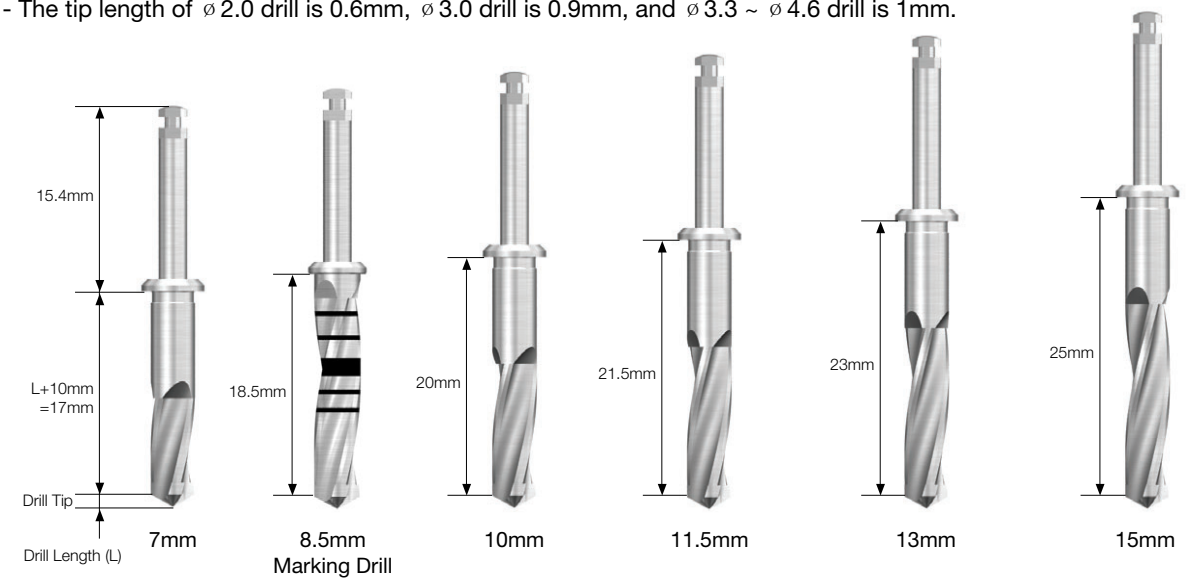

# OsstemGuide™ Surgical Components

## 4. OsstemGuide™ Mount

- The exclusively designed mount for OsstemGuide surgery is to be used for implantation after combination with the fixture. The configuration is different by the specification of the implant system.  
Use it to meet the color of the sleeve combined with OsstemGuide template.

System	Fixture Dia.	Code	Color
TS/GS	3.5	QGHGMM	Yellow
	4.0 / 4.5	QGHGMR	Green
	5.0	QGHGMW	Purple

System	Platform Dia.	G/H	Code	Color
SS	4.8	1.8	OGSSMR18	Green
		2.8	OGSSMR28	Green
	6.0	2.0	OGSSMW20	Purple

System	Fixture Dia.	Code	Color
US	3.5	OGUSMM	Yellow
	4.0 / 4.5	OGUSMR	Green
	5.0	OGUSMW	Purple

### TS / GS Mount



### SS Mount



### US Mount



## 5. OsstemGuide™ Cylinder Guide

- It is the exclusively designed prosthetic components for OsstemGuide and is used with combination with common fixture lab analog.  
Use it to meet the color of the sleeve combined with OsstemGuide template.

System	Fixture Dia.	Code	Color
TS/GS	3.5	QGHGCGM	Yellow
	4.0 / 4.5	QGHGCGR	Green
	5.0	QGHGCGW	Purple

System	Fixture Dia.	G/H	Code	Color
SS	4.8	1.8	OGSSCGR18	Green
		2.8	OGSSCGR28	Green
	6.0	2.0	OGSSCGW20	Purple

System	Fixture Dia.	Code	Color
US	3.5	OGUSCGM	Yellow
	4.0 / 4.5	OGUSCGR	Green
	5.0	OGUSCGW	Purple

### TS / GS Cylinder Guide



### SS Cylinder Guide



### US Cylinder Guide



# AutoBone Collector

## Components

### AutoBone Collector

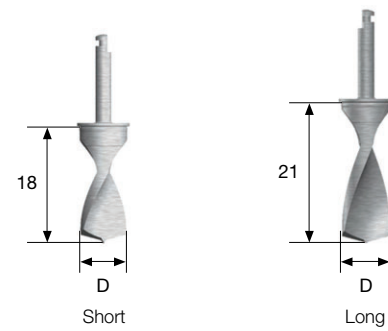

Name	D	Code
Drill [Short]	ø 7.0	ABCD7014S
Stopper [Short]	ø 7.0	ABCSNST7144S
Drill [Long]	ø 7.0	ABCD7017L
Stopper [Long]	ø 7.0	ABCSNST7174L

- Drill length : Long, Short.
- Drill speed : 300~600rpm
- Caution : Recommend sterilize in an autoclave before surgery for drill and stopper.

### Bone Ejector



Name	Code
Bone Ejector	ABBE71L

- Ejector the harvested Bone in stopper.

# Screw removal KIT (OSSVK)

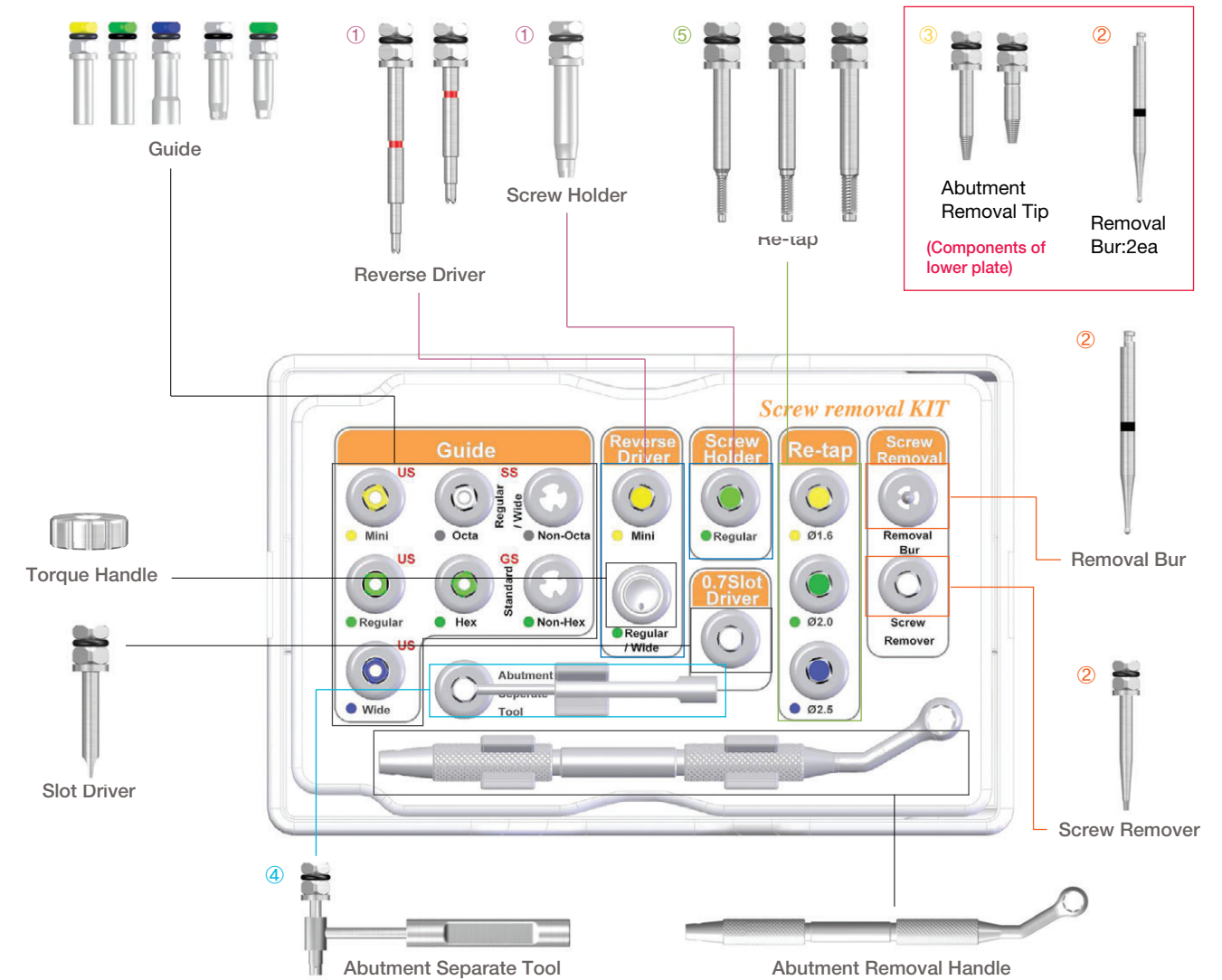

		MODE	Usable Tool
①	Screw Fracture	Torque-free	Guide, Abutment Removal Handle, Reverse Driver, Screw Holder, Connector
		Wedging	Guide, Abutment Removal Handle, Removal Bur, Screw Remover
③	Abutment Fail	Fracture	Abutment Removal Handle & Tip
		Wedging	Abutment Separate Tool
⑤	Fixture Fail	Thread Damage	Re-tap

# Screw removal Tools for OSSTEM IMPLANT

## Reverse Driver



	Mini	Regular/ Wide
Short	-	ORVDRS
Long	ORVDML	ORVDRL

- Packing Unit : each part
- Tool for removing broken screws
- This tool should be used together with the guide for each system
- When the marked part of the reverse drill is exposed above the guide connected to the fixture, make use of the screw-older to remove the broken Screws
- Hand type
- Mode: Counter clockwise
- Lifecycle: Ten uses
- Color coding for easy discrimination of the specifications  
Mini: **Yellow**, Regular/ Wide : **Green**

## Guide

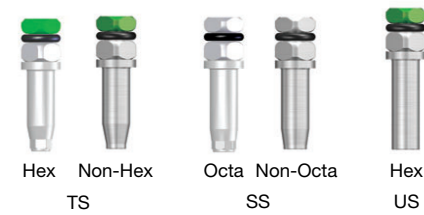

		Mini	Regular	Wide
TS	Non-Hex	OGGMN	OGGSN	-
	Hex	OGGM	OGGS	-
SS	Non-Octe	-	OSGRN	
	Octe	-	OSGR	
US	Hex	OUGM	OUGR	OUGW

- Packing Unit : each part
- Guide used to prevent the reverse driver, the removal bur and the re-tap from centering or vibrating
- The guide should be used after connecting to the abutment removal handle
- Color coding for easy discrimination of the specifications  
Mini: **Yellow**, Regular : **Green**, Wide : **Blue**

## Screw Holder



	Mini	Regular	Wide
Code	OSHM	OSHR	OSHW

- Packing Unit : each part
- This tool is used for removal of fractured screw; expose the fractured screw by 1-2 threads using a reverse driver, push it on the fractured screw for combination, and remove the fractured screw.
- Color coding for easy discrimination of the specifications  
Mini: **Yellow**, Regular : **Green**, Wide : **Blue**

## Re-tap

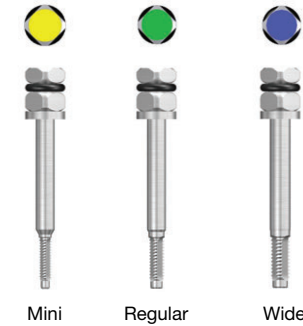

	Mini(M1.6)	Regular(M2.0)	Wide(M2.5)
Code	ORTM	ORTR	ORTW

- Packing Unit : each part
- Tool used for forming new threads if a screw is not connected because the threads inside the fixture have been damaged
- Color coding for easy discrimination of the specifications  
Mini: **Yellow**, Regular : **Green**, Wide : **Blue**

## Abutment Removal Tip

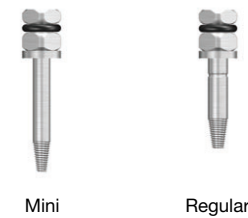

	Mini	Regular
Code	OARTM	OARTR

- Packing Unit : each part
- This tool is used when part of a broken abutment or mount gets caught in the fixture
- Remove the fragment by shaking it with a forceps when connecting the fragment into the hole of the broken abutment, and then turn the connected part counter clock wise and fix the part
- This tool is also used for removing a screw if it is not possible to remove the screw because the hex of the screw has slipped in the case of the Mini  
- It is possible to remove the screw by turning the screw counterclockwise and fixing the screw after connecting it to the slipped hex

\* Mini: Makes it possible to remove a screw whose hex has slipped

## ABT Removal Tool



Code	OARH

- Packing Unit : each part
- This tool should be used in conjunction with the guide



# Screw removal Tools for OSSTEM IMPLANT

## Slot Driver



Code	OTSD07
------	--------

- Packing Unit : each part
- Tool to be used after forming a slot with a bur of  $\varnothing 0.8$  if it is not possible to exert force with the driver because of damage to the hex of the healing abutment, the cover screw and the abutment screw

## Torque Handle



Code	MSTH
------	------

- Packing Unit : each part
- This tool is used for initial manual installation after connecting it to the connection section of the torque driver

## Removal Bur



Code	ORB
------	-----

- Packing Unit : each part
- Tool for removing broken screws
- This tool is used for forming a hole on the broken surface of the screw if it is not possible to remove the screw with a reverse driver
- Rotation direction: Clockwise
- Recommended rotation speed: 1500 ~5000 rpm
- This tool should be used in conjunction with the guide
- It is necessary to minimize the generation of heat by pumping and water injection, and to remove any chips left behind after removing the screw with a suction tool

## Screw Remover



Code	OSR
------	-----

- Packing Unit : each part
- Rotate the screw remover in the reverse direction in the hole of the broken surface of the screw formed by the removal bur to remove a broken screw
- Mode: Counter clockwise

## Transfer Abutment Separate Tool

Driver



Body



Type	Code
Driver	TASD
Body	TASB
Set	TAST

- Packing Unit : each part
- This tool is used for removing the transfer abutment of non-hex-type caught in the fixture as a result of contact with a Morse Taper
- The terminal of the body is the Mini. The standard tool is inserted into the grooves in two stages in common use
- Insert the separate tool body into the hole inside the abutment after removing the abutment screw, and tighten the driver in a clockwise direction to combine the body and the abutment for easy separation Use the tool after connecting the ratchet wrench to the driver, if it is hard to separate

# Drilling Sequence for TSIII / GSIII RBM / SSIII SA / SSIII RBM / USIII SA / USIII RBM

## TSIII / GSIII RBM / SSIII SA / SSIII RBM / USIII SA / USIII RBM Fixture (Straight Drill)

### ∅ 3.5mm Fixture (Length :10mm)

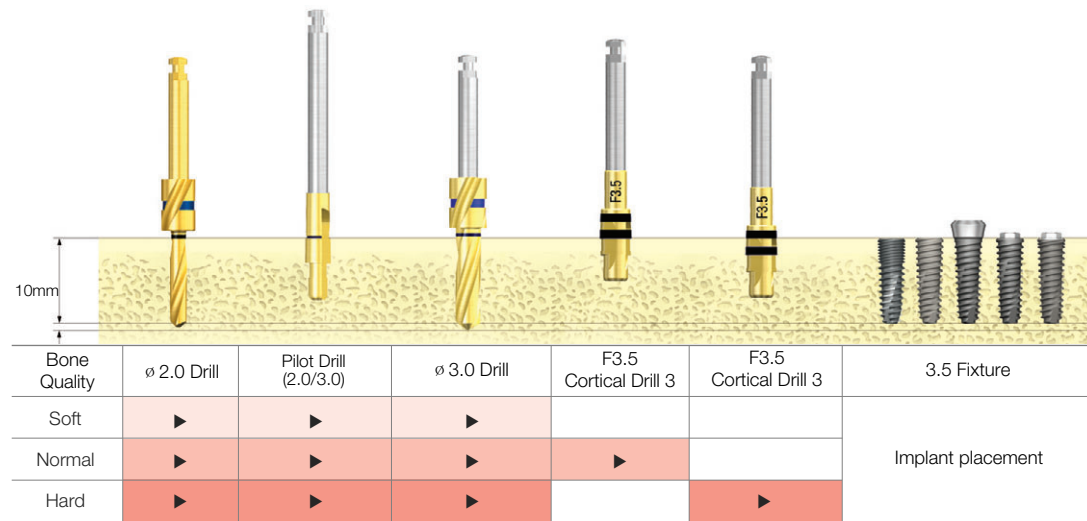

### ∅ 4.0mm Fixture (Length :10mm)

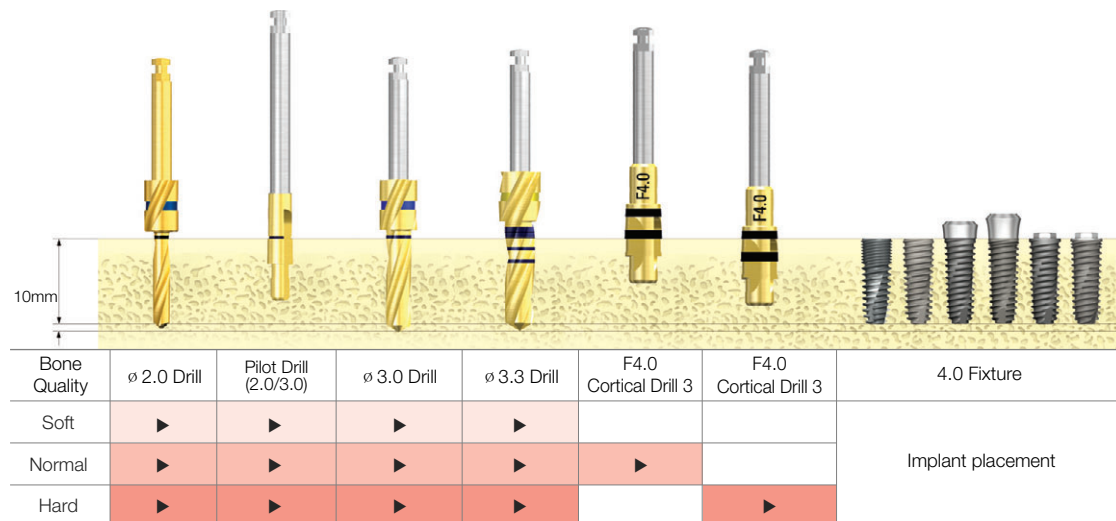

※ Recommended implant torque : 40Ncm or less

※ TSIII HA Fixture, SSIII Fixture (Recommended implant torque : 35Ncm or less)  
- It may crack or separate HA coating layer in case of hard bone and the use is not guided.

※ TS/GS fixture implant depth guide

- In case of normal or higher-quality bone, it is recommended to implant deeper than bone level by 1mm or less.
- In case of soft bone, it is recommended to implant to meet the bone level for maintenance of anchoring force.

### ∅ 4.5mm Fixture (Length :10mm)

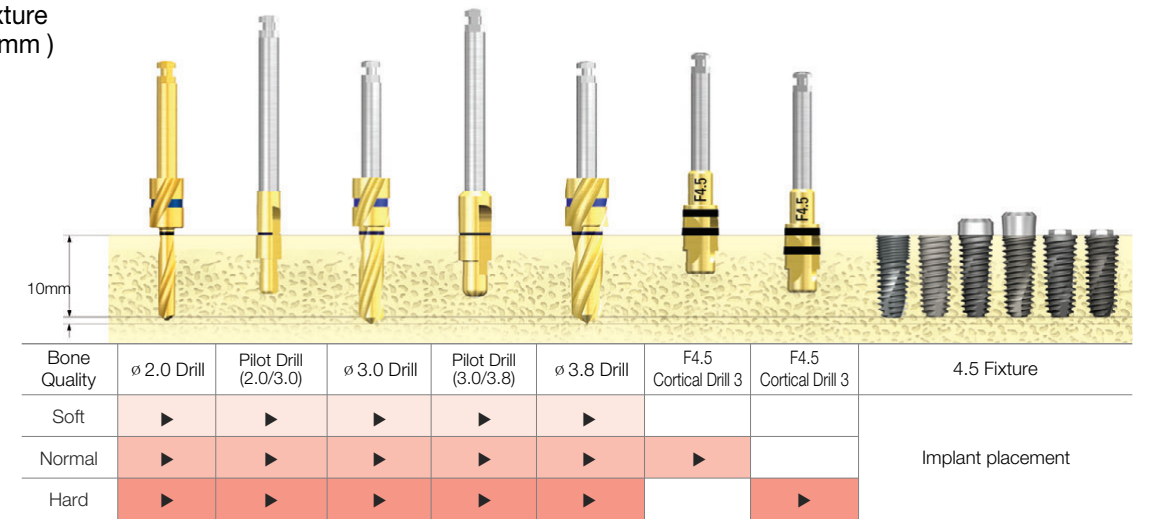

### USIII Wide PS Fixture ∅ 4.5mm Fixture (Length :10mm)

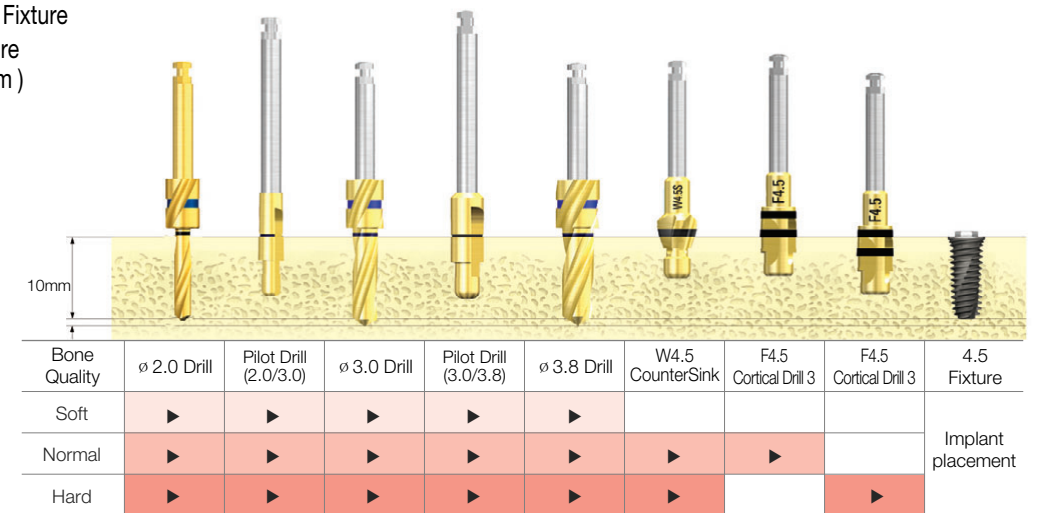

※ CounterSink is available as a single unit for Wide PS 4.5 of USIII Fixture.  
(Produce code : USSCS45W / Recommended drilling speed : 300rpm)

### ∅ 5.0mm Fixture (Length :10mm)

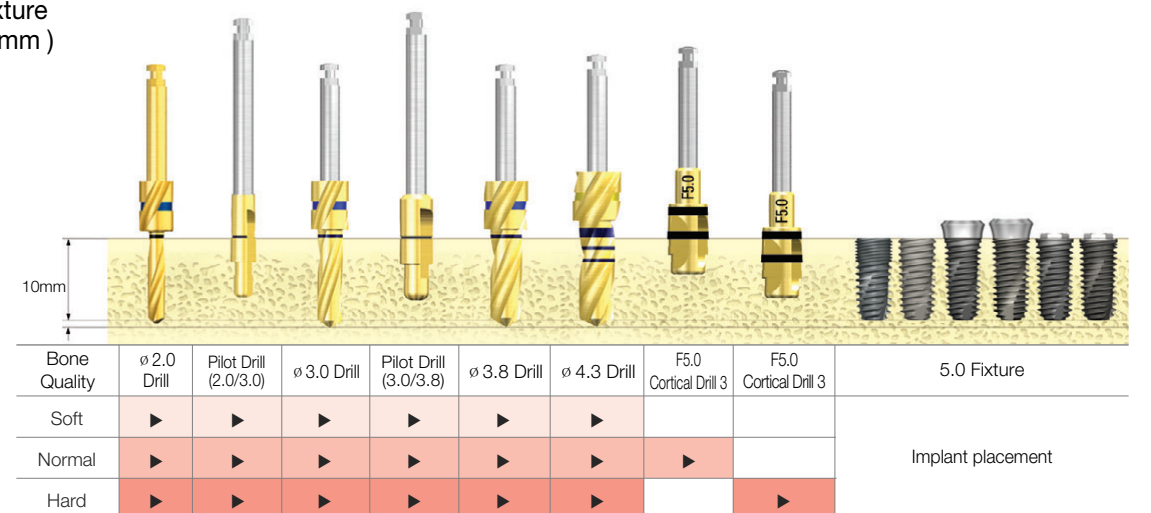

※ TS/GS fixture implant depth guide

- In case of normal or higher-quality bone, it is recommended to implant deeper than bone level by 1mm or less.
- In case of soft bone, it is recommended to implant to meet the bone level for maintenance of anchoring force.

# Drilling Sequence for TSIII / GSIII RBM / SSIII SA / SSIII RBM / USIII SA / USIII RBM

## TSIII / GSIII RBM / SSIII SA / SSIII RBM / USIII SA / USIII RBM (Taper Drill)

### ∅ 3.5mm Fixture ( Length :10mm )

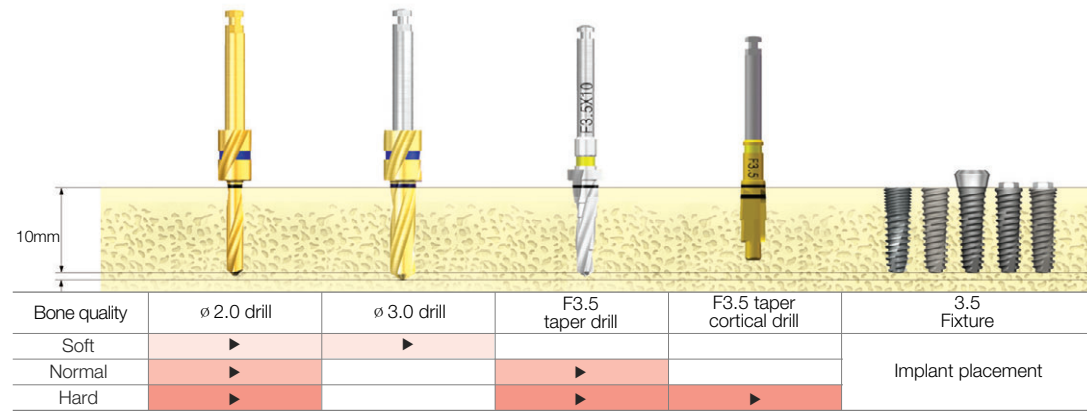

### ∅ 4.0mm Fixture ( Length :10mm )

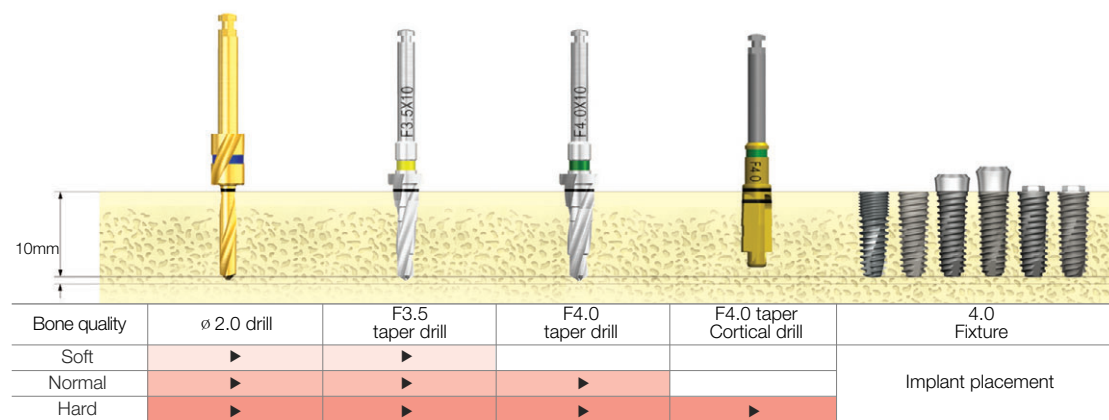

#### ※ Taper Cortical Drill

- The lower end of marking line is used for implantation of 8.5mm or smaller fixture.
- The upper end of marking line is used for implantation of 10mm or larger fixture.

#### ※ Recommended implant torque : 40Ncm or less

#### ※ TSIII HA Fixture, SSIII Fixture (Recommended implant torque : 35Ncm or less)

- It may crack or separate HA coating layer in case of hard bone and the use is not guided.

#### ※ TS/GS fixture implant depth guide

- In case of normal or higher-quality bone, it is recommended to implant deeper than bone level by 1mm or less.
- In case of soft bone, it is recommended to implant to meet the bone level for maintenance of anchoring force.

### ∅ 4.5mm Fixture ( Length :10mm )

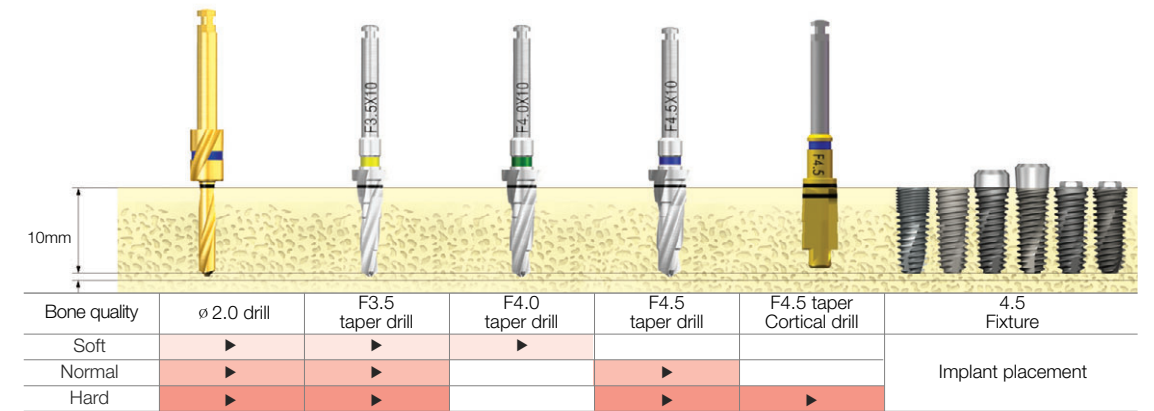

### US III Wide PS Fixture ∅ 4.5mm Fixture ( Length :10mm )

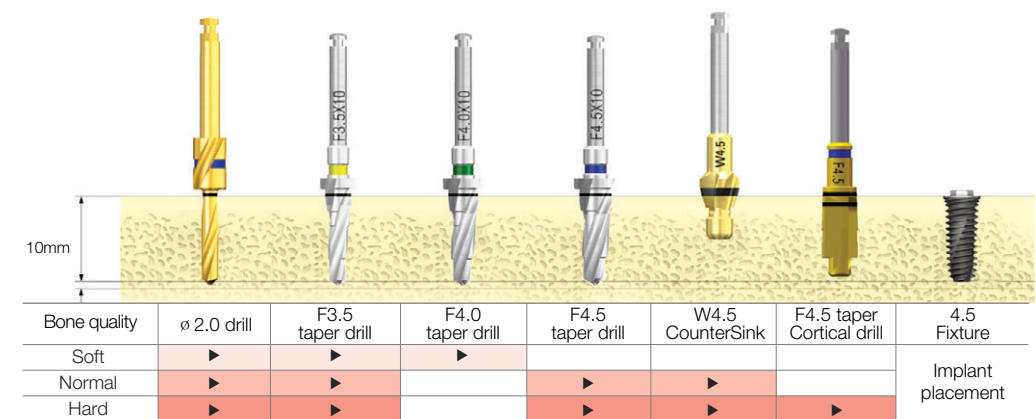

※ CounterSink is available as a single unit for Wide PS 4.5 of USIII Fixture.  
(Produce code : USSCS45W / Recommended drilling speed : 300rpm)

### ∅ 5.0mm Fixture ( Length :10mm )

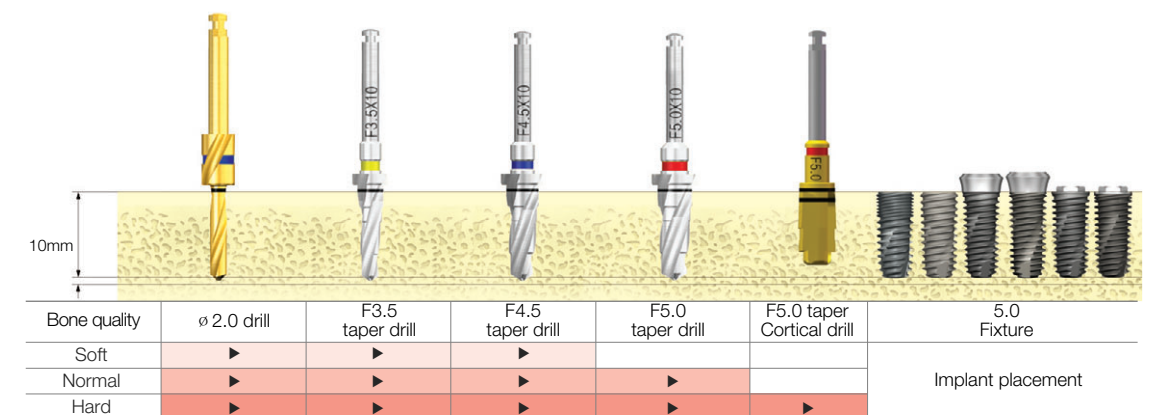

#### ※ TS/GS fixture implant depth guide

- In case of normal or higher-quality bone, it is recommended to implant deeper than bone level by 1mm or less.
- In case of soft bone, it is recommended to implant to meet the bone level for maintenance of anchoring force.

# Drilling Sequence for TSII / GSII RBM / SSII SA / USII SA

## TSII / GSII RBM / SSII SA / USII SA Fixture

∅ 3.5mm Fixture ( Length :10mm )

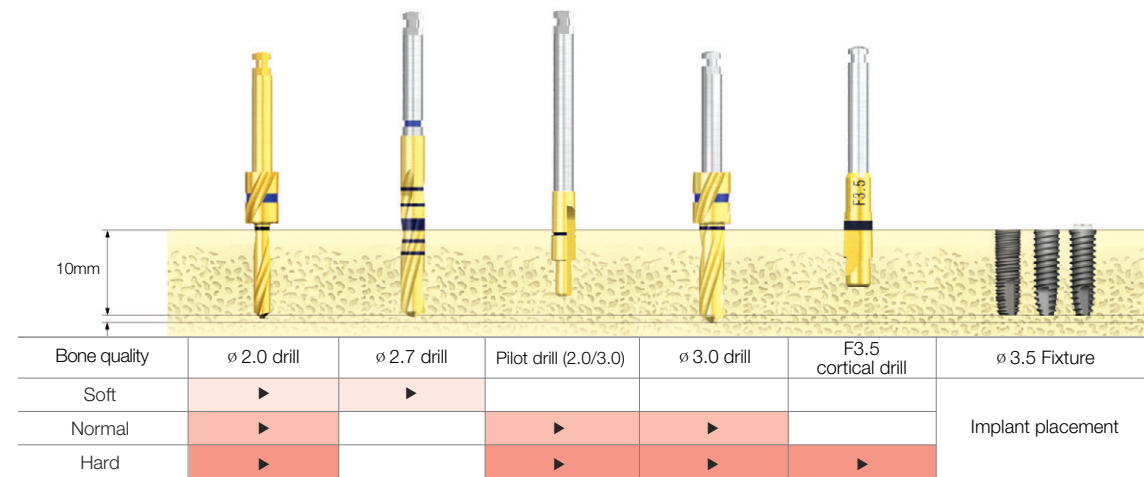

∅ 4.5mm Fixture ( Length :10mm )

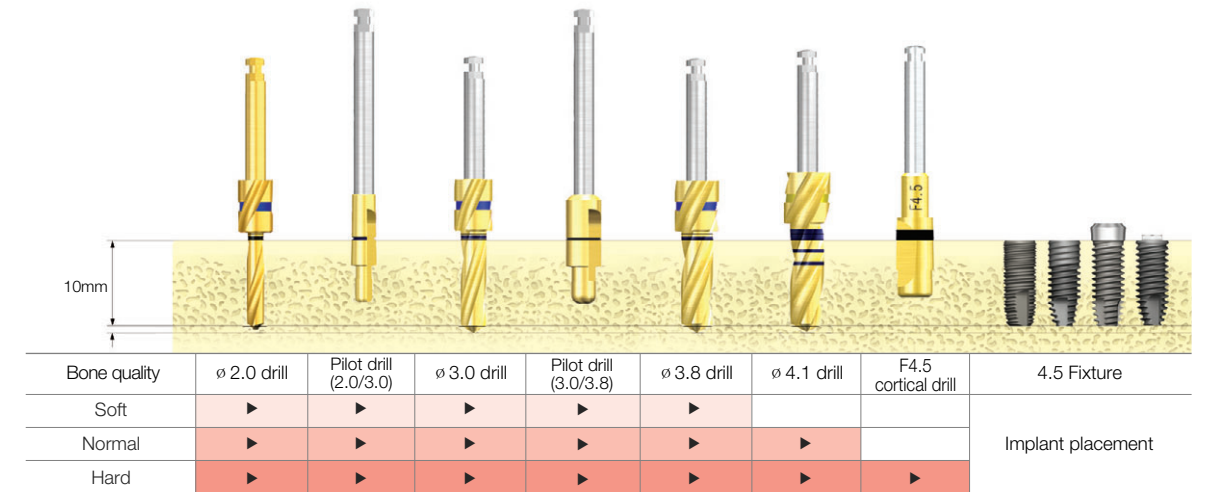

∅ 4.0mm Fixture ( Length :10mm )

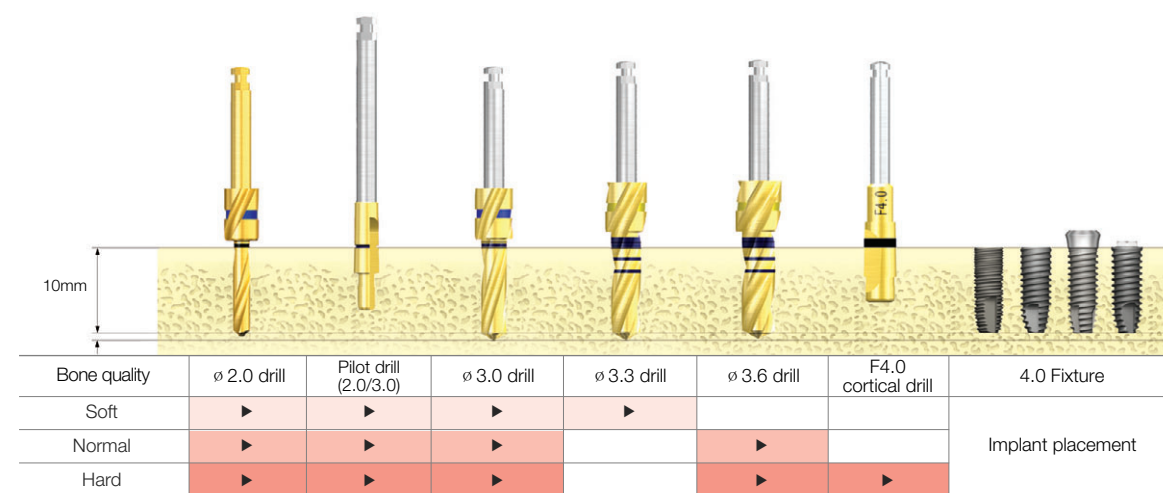

∅ 5.0mm Fixture ( Length :10mm )

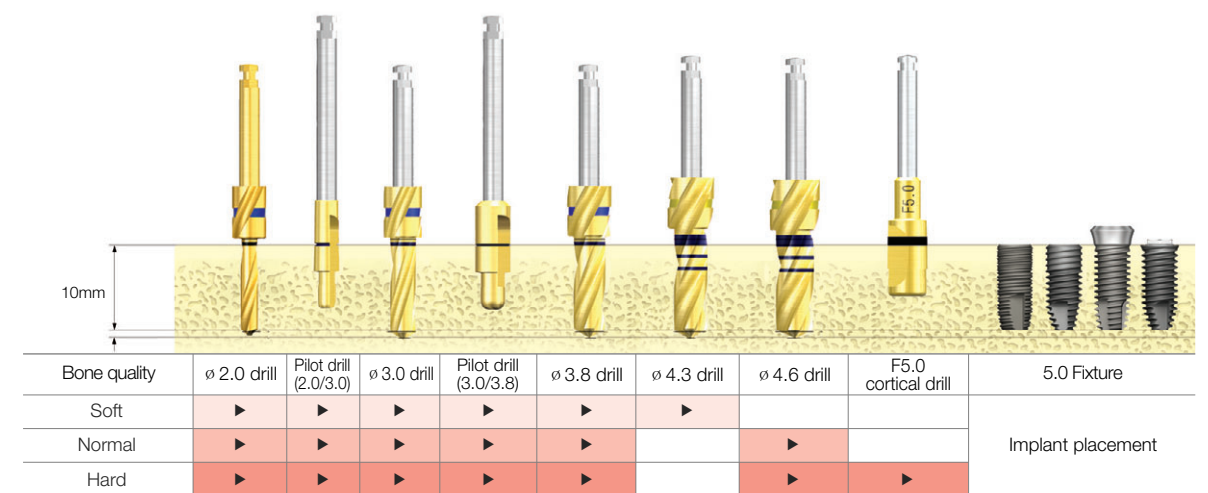

※ Recommended implant torque : 40Ncm or less

※ TS/GS fixture implant depth guide

- In case of normal or higher-quality bone, it is recommended to implant deeper than bone level by 1mm or less.
- In case of soft bone, it is recommended to implant to meet the bone level for maintenance of anchoring force.

※ TS/GS fixture implant depth guide

- In case of normal or higher-quality bone, it is recommended to implant deeper than bone level by 1mm or less.
- In case of soft bone, it is recommended to implant to meet the bone level for maintenance of anchoring force.

# Drilling Sequence for TSIV

## TSIV Fixture (Straight Drill)

### ∅ 4.0mm Fixture ( Length : 10mm )

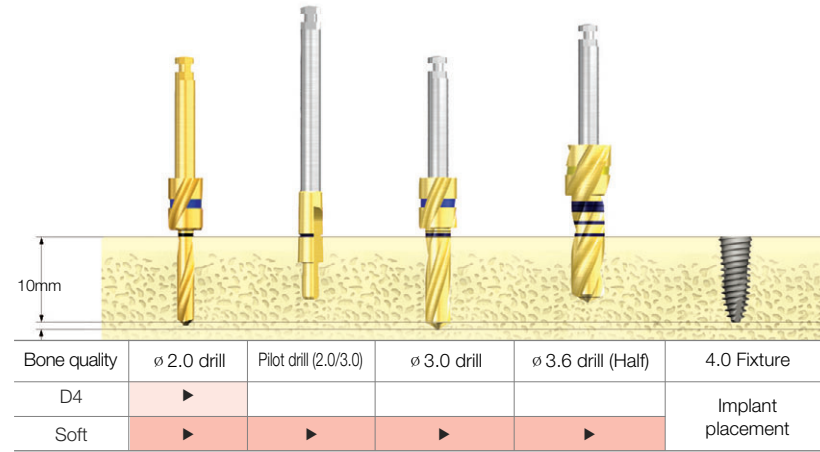

### ∅ 4.5mm Fixture ( Length :10mm )

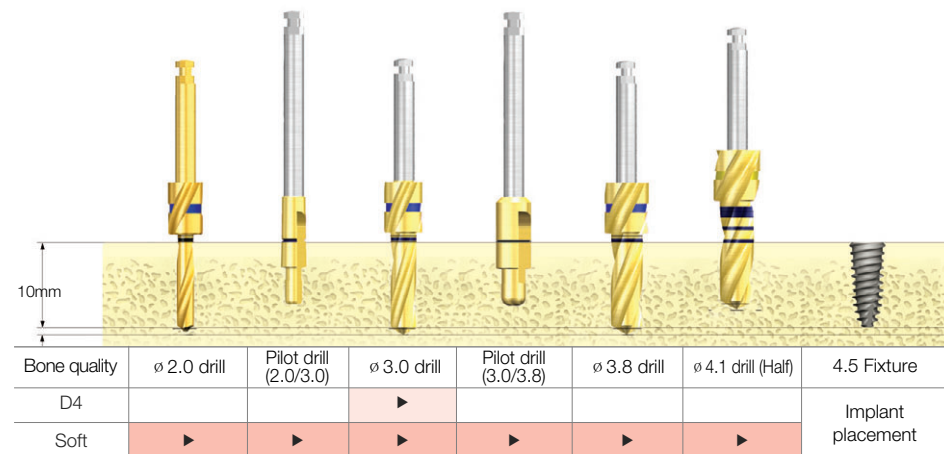

### ∅ 5.0mm Fixture ( Length :10mm )

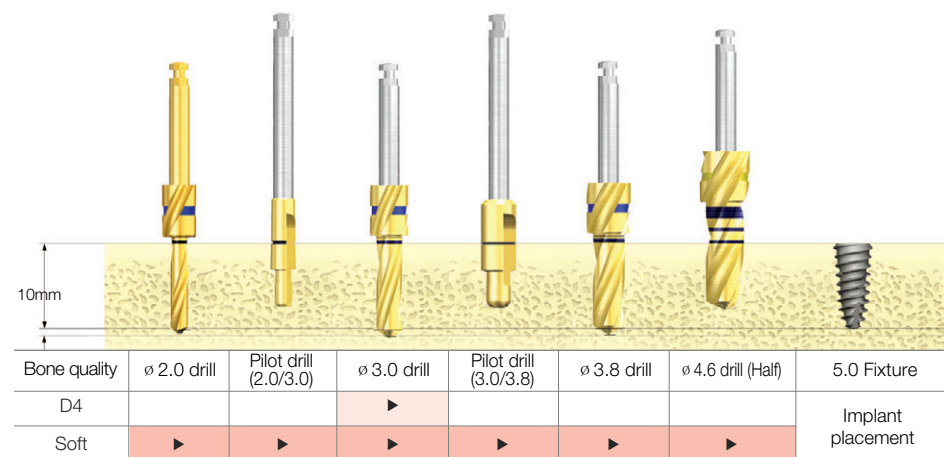

## TSIV Fixture (Taper Drill)

### ∅ 4.0mm Fixture ( Length : 10mm )

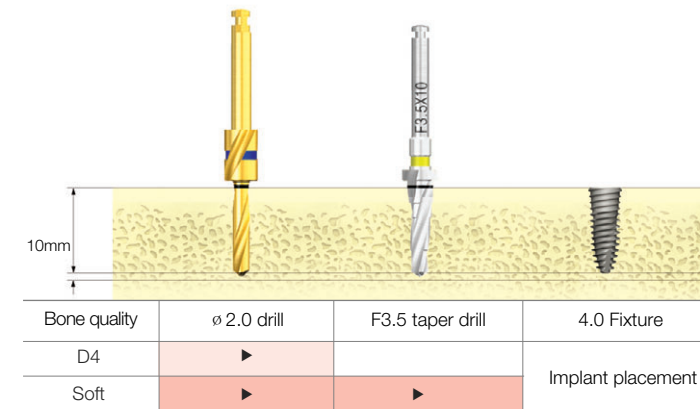

### ∅ 4.5mm Fixture ( Length :10mm )

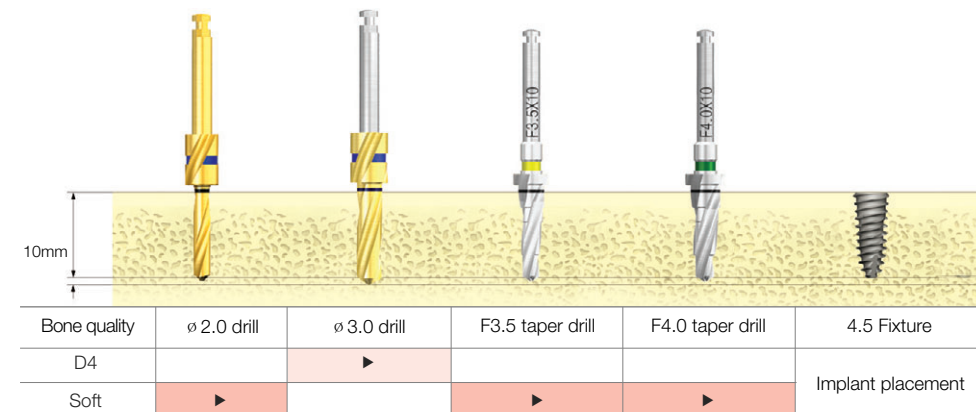

### ∅ 5.0mm Fixture ( Length :10mm )

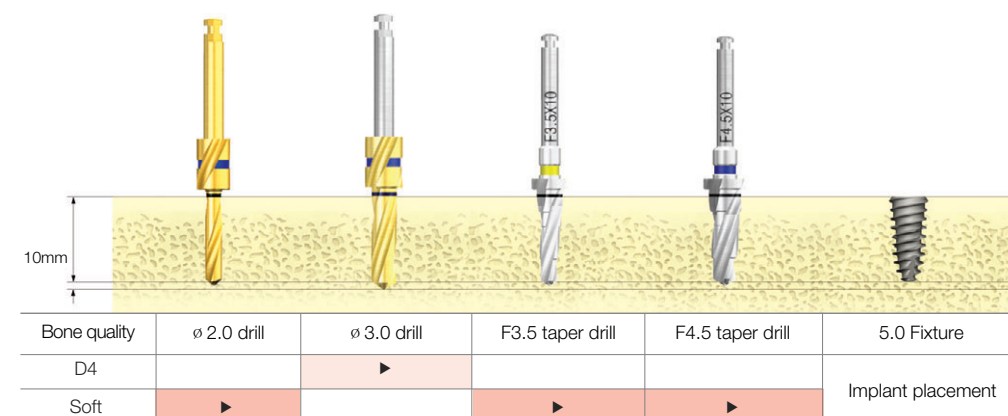

- ※ Recommended implant torque : 40Ncm or less
- ※ TSIV Fixture is used for implantation in maxillary sinus or soft bone and, in case of normal or higher-quality bone, guide is not required.
- ※ TSIV Fixture has large thread pitch and high implantation speed; therefore, it is recommended to perform implantation with reduction of the speed to 15rpm or lower level.

- ※ Recommended implant torque : 40Ncm or less
- ※ TSIV Fixture is used for implantation in maxillary sinus or soft bone and, in case of normal or higher-quality bone, guide is not required.
- ※ TSIV Fixture has large thread pitch and high implantation speed; therefore, it is recommended to perform implantation with reduction of the speed to 15rpm or lower level.

# Drilling Sequence for SSII RBM

## SSII RBM Fixture

∅ 3.3mm Fixture ( Length : 10mm )

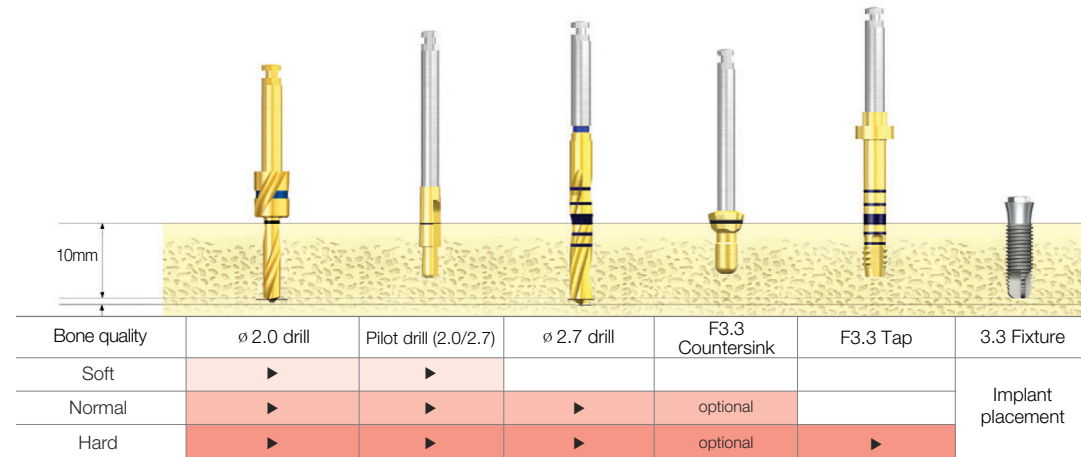

∅ 4.1mm Fixture ( Length : 10mm )

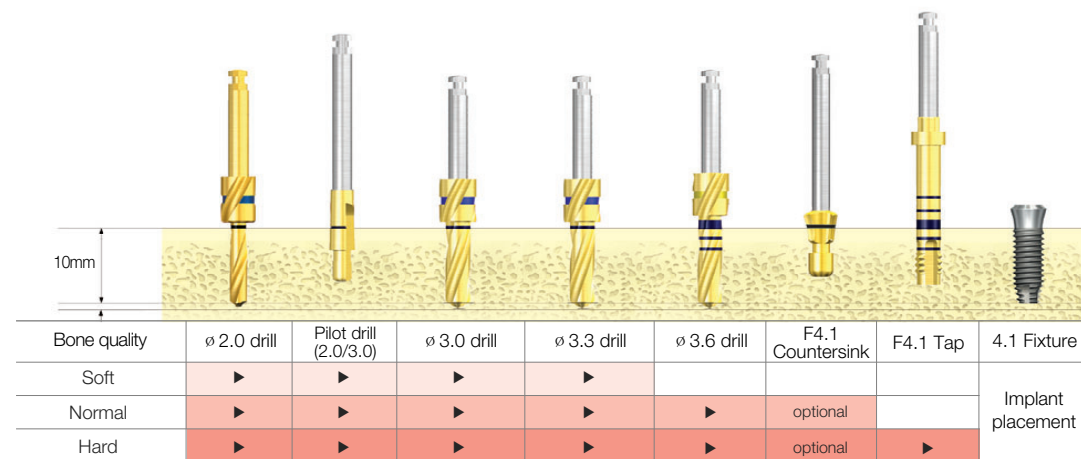

∅ 4.8mm Fixture ( Length : 10mm )

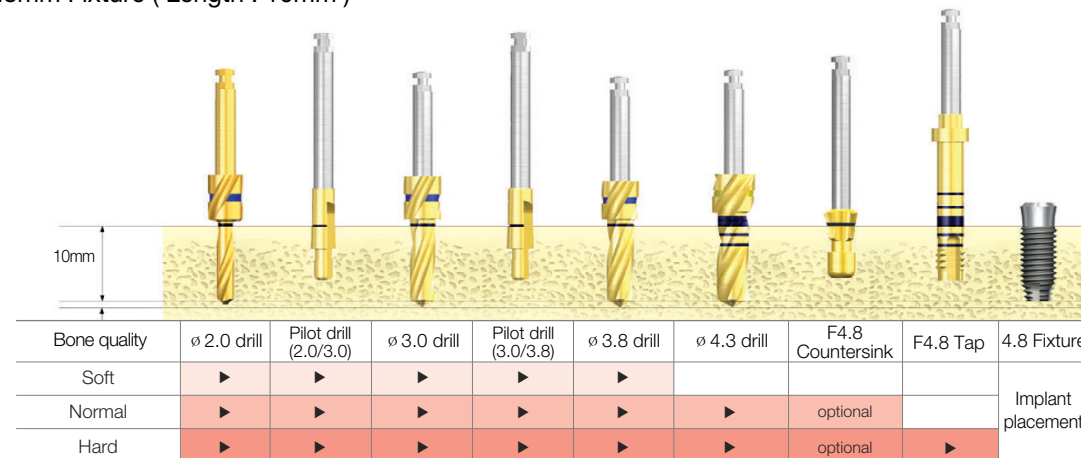

※ Recommended implant torque : 40Ncm or less

# Drilling Sequence for USII RBM

## USII RBM Fixture

∅ 3.3mm Fixture ( Length : 10mm )

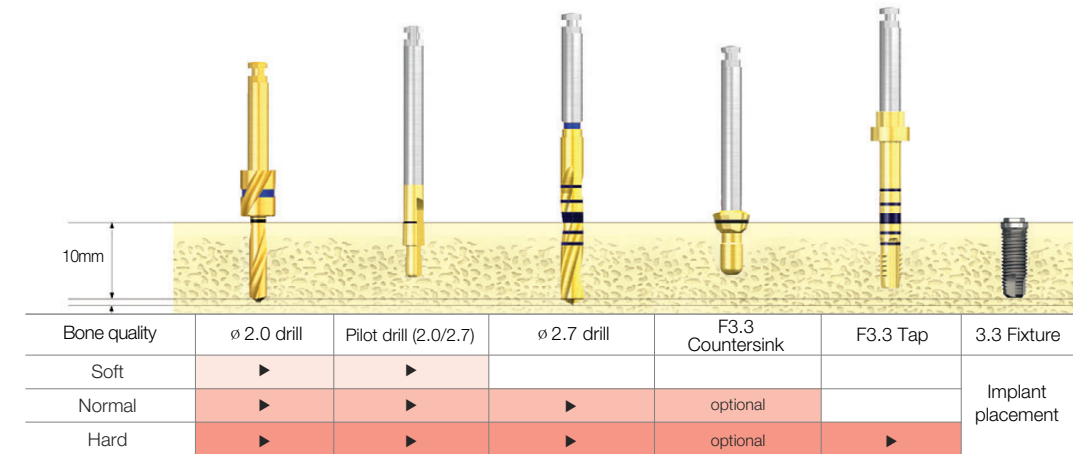

∅ 3.75mm Fixture ( Length : 10mm )

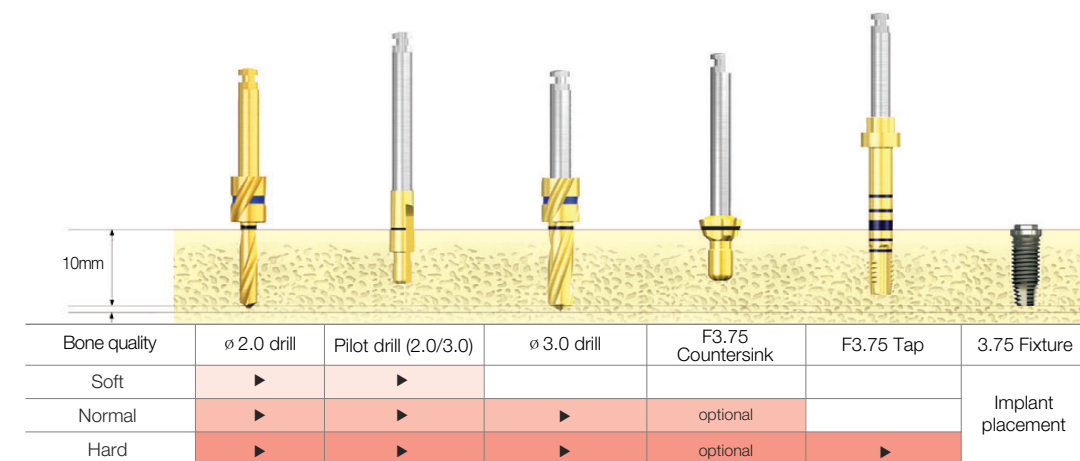

※ Recommended implant torque : 40Ncm or less

# Drilling Sequence for USII RBM

## USII RBM Fixture

∅ 4.0mm Fixture ( Length : 10mm )

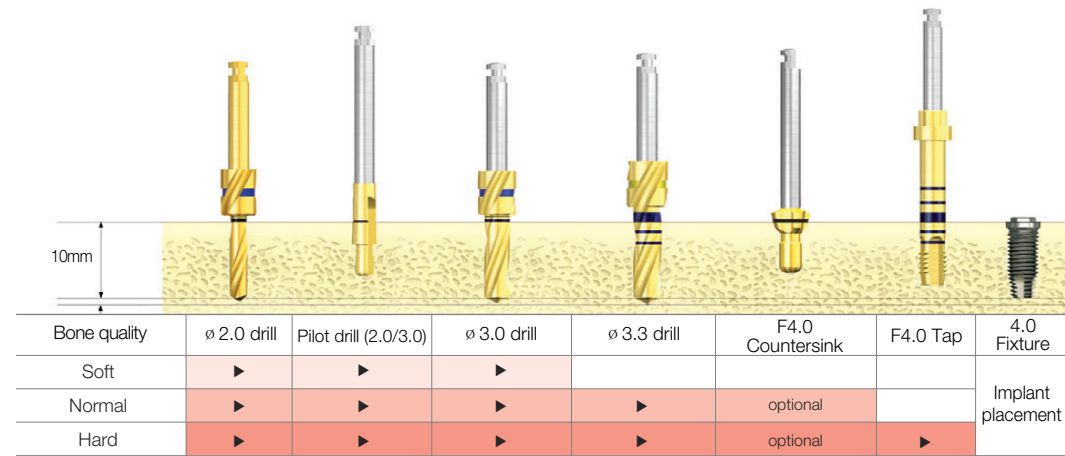

# Drilling Sequence for Ultra-Wide®

## GSII / SSII / USII RBM Ultra-Wide® Fixture

∅ 6.0 mm Fixture ( Length : 10mm )

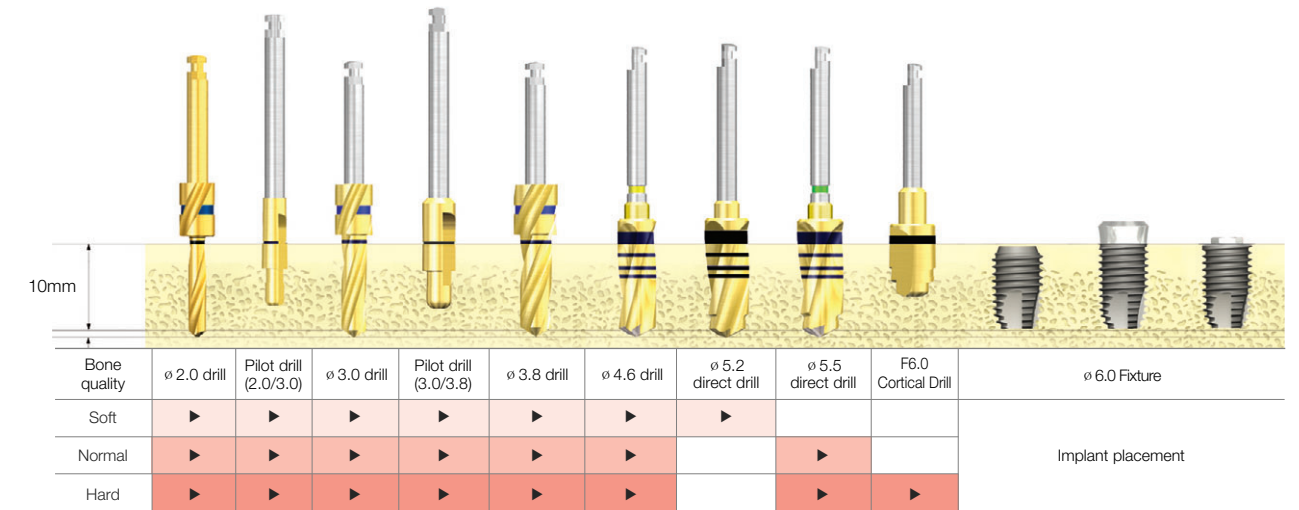

∅ 5.0mm Fixture ( Length : 10mm )

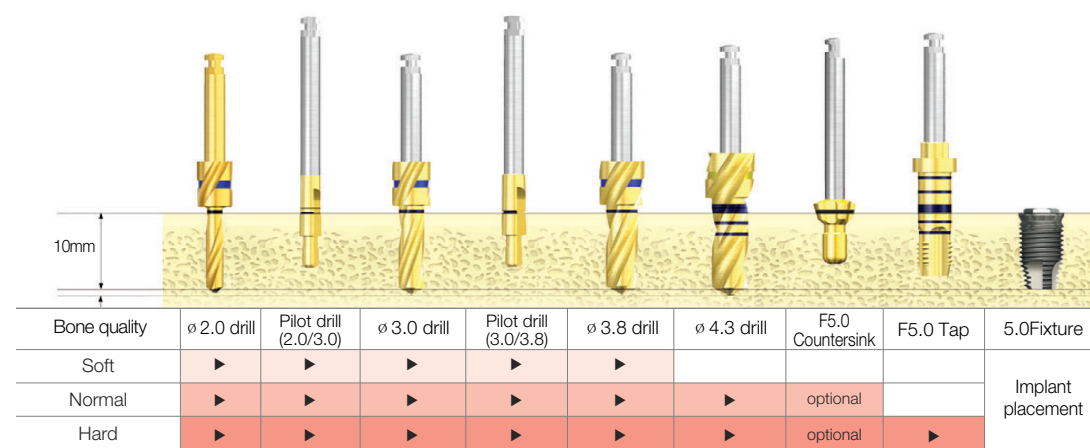

∅ 7.0 mm Fixture ( Length : 10mm )

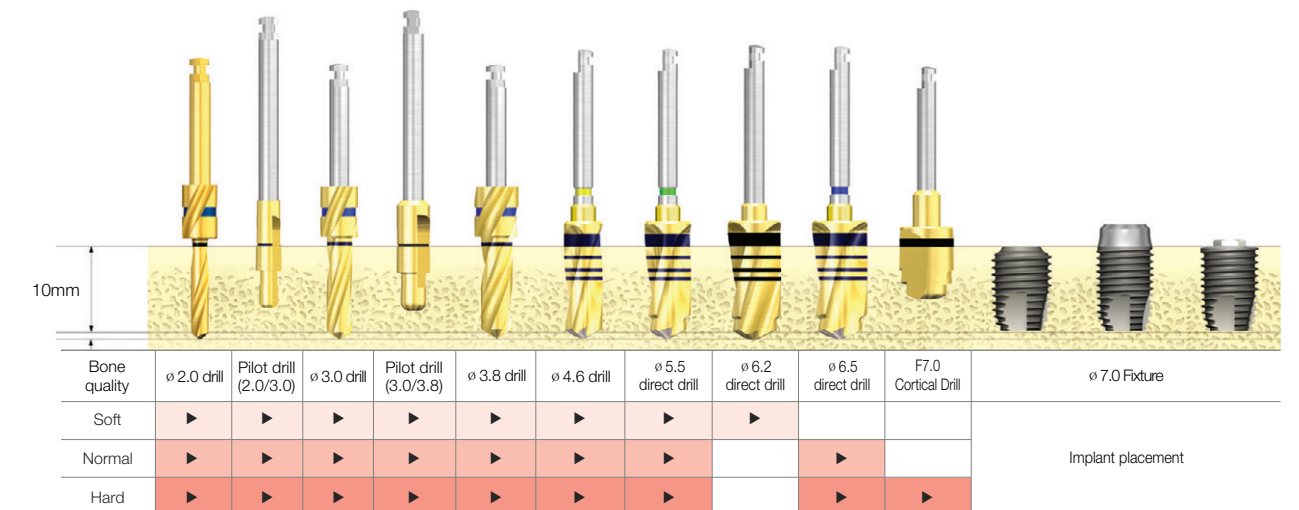

※ Recommended implant torque : 40Ncm or less

※ Recommended implant torque : 40Ncm or less

# Drilling Sequence for Ultra-Wide®

## SSII / USII RBM Ultra-Wide® Fixture

### Drilling Sequence with Trepine in the healed mature bone (∅ 6.0 Ultra-Wide® fixture, Length : 10mm)

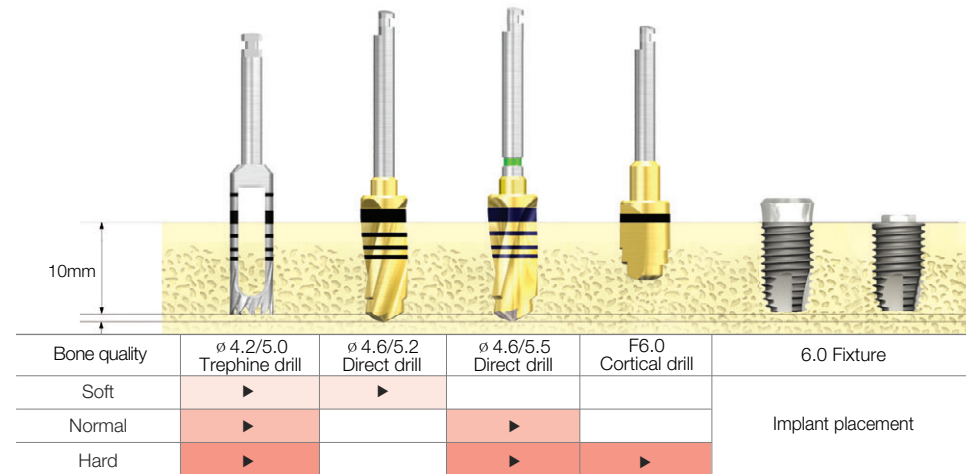

### Immediate placement at the extraction socket (∅ 6.0 Ultra-Wide® fixture, Length : 10mm)

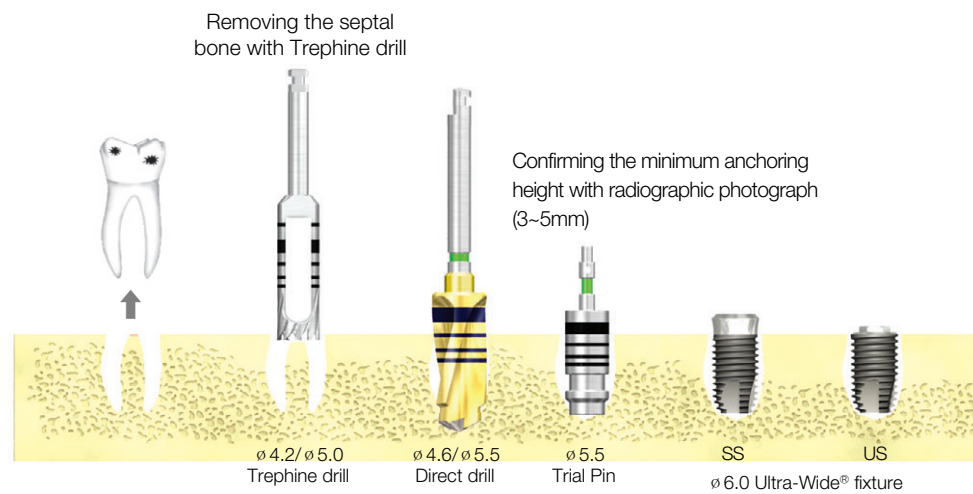

### Immediate replacement of the failed implant (∅ 6.0 Ultra-Wide® fixture, Length : 10mm)

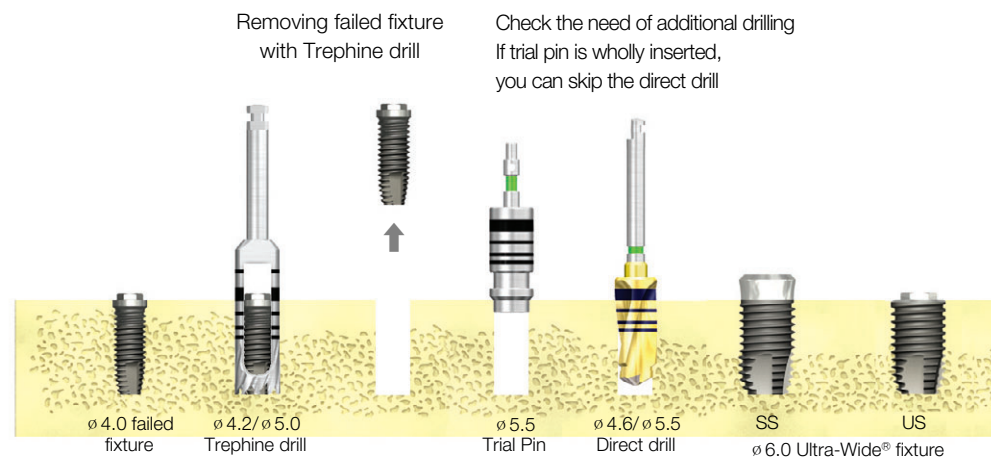

## TSIII SA Ultra-Wide® Fixture (Straight Drill)

### ∅ 6.0 mm Fixture (Length : 10mm)

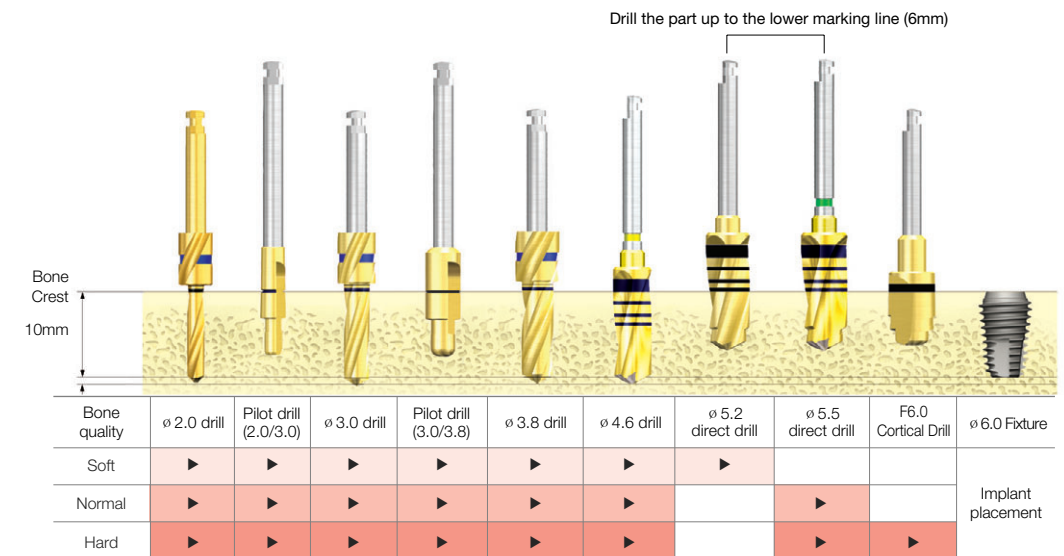

### ∅ 7.0 mm Fixture (Length : 10mm)

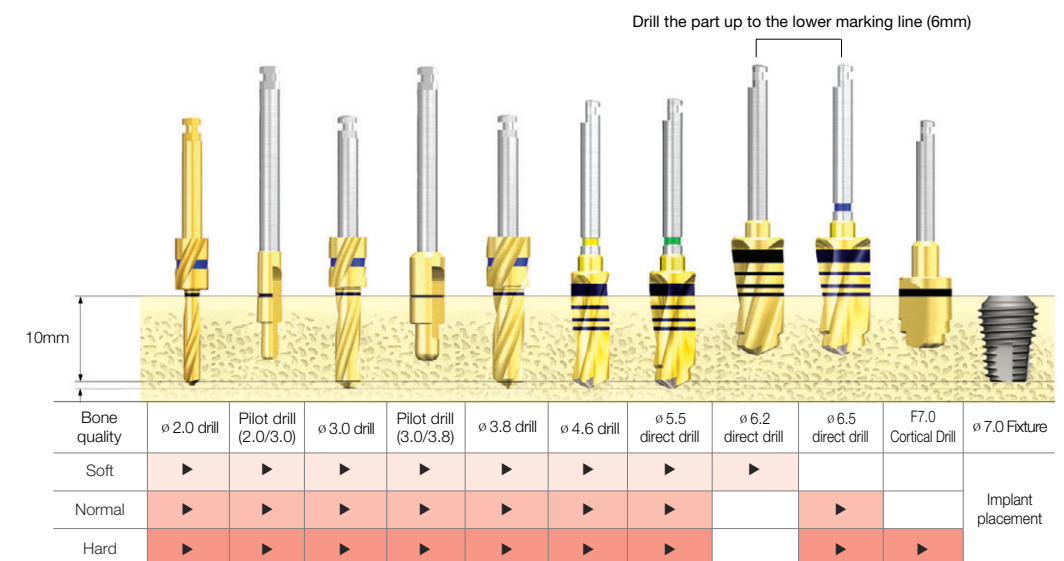

※ Recommended implant torque : 40Ncm or less

※ TS/GS fixture implant depth guide

- In case of normal or higher-quality bone, it is recommended to implant deeper than bone level by 1mm or less.
- In case of soft bone, it is recommended to implant to meet the bone level for maintenance of anchoring force.



# Drilling Sequence for Ultra-Wide®

## TSIII Ultra-Wide® Fixture (Taper Drill)

∅ 6.0 mm Fixture (Length : 10mm)

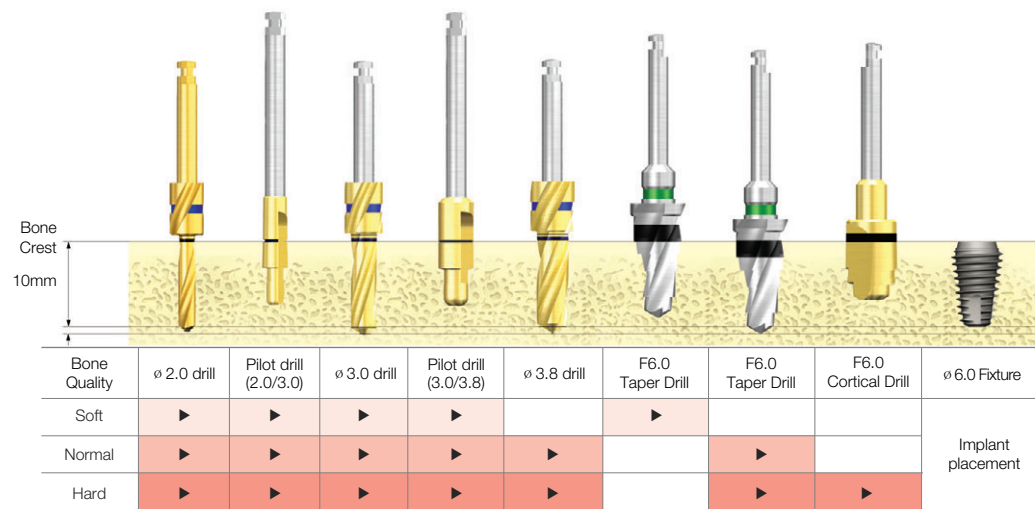

∅ 7.0 mm Fixture (Length : 10mm)

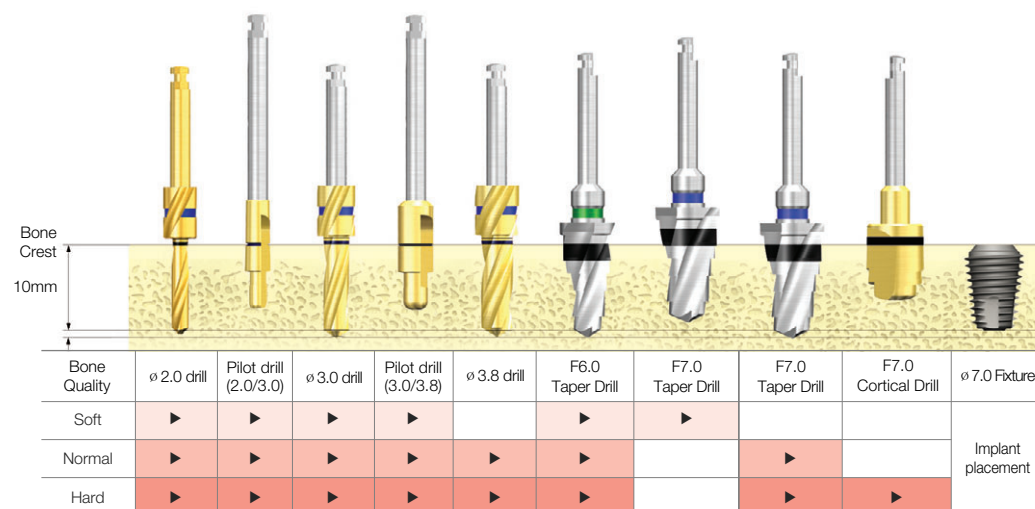

※ Recommended implant torque : 40Ncm or less

※ TS/GS fixture implant depth guide

- In case of normal or higher-quality bone, it is recommended to implant deeper than bone level by 1mm or less.
- In case of soft bone, it is recommended to implant to meet the bone level for maintenance of anchoring force.

# How to manage KIT

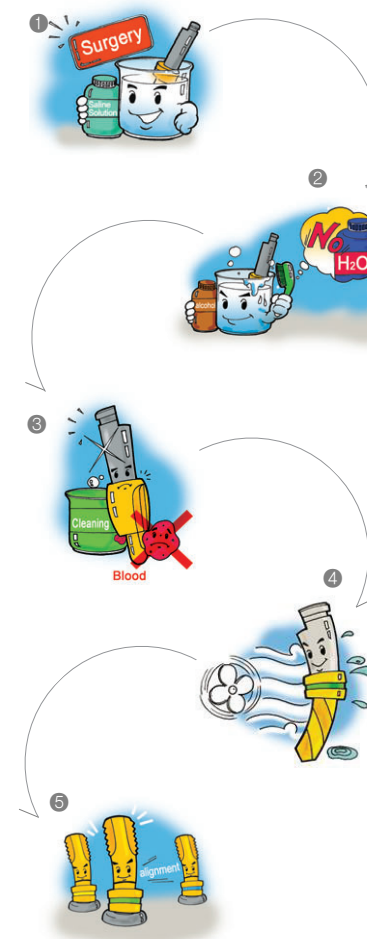

① During operation, keep used tools in saline solution or in distilled water.

② When the operation has been completed, soak all the used tools in alcohol for washing.

**Caution** Washing with hydrogen peroxide is prohibited. Exposure to hydrogen peroxide may discolor the laser marking and TiN coating.

③ Wash blood stains and other foreign matter clean with distilled water or flowing water.

④ Remove the moisture with a dry cloth or a hot air blower.

⑤ Set the dried tools in the KIT case. (Refer to the color coding for setting the tools in the kit case.)

⑥ After setting, sterilize the kit in an autoclave at 132°C for 15 minutes and store room temperature.

**Caution:** After an operation, separate all the tools used in the operation immediately, and wash them before storage. It is highly recommended to sterilize the Surgical KIT again before an operation (temperature: 132°C, time: 15 min) The warranty period of the Surgical KIT is One Year after first opening the package, and the warranty cycles of the Drills and Drivers is 50 cycles.

# Actual Dimensions of TSIII / GSIII RBM / SSIII SA / SSIII RBM / USIII SA / USIII RBM

# Actual Dimensions of TSII / USII SA

TSIII / GSIII RBM / SSIII SA / SSIII RBM / USIII SA / USIII RBM Fixture

TSII / USII SA Fixture

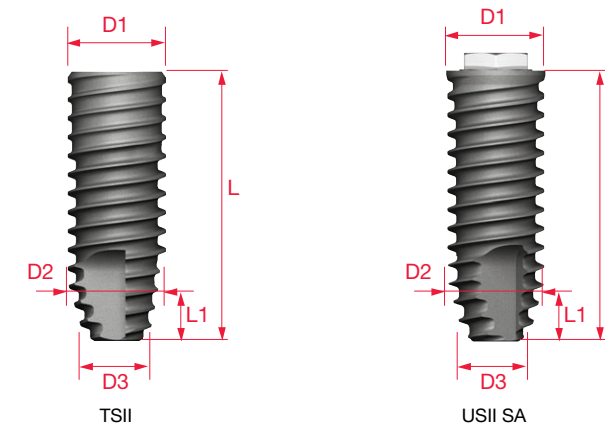
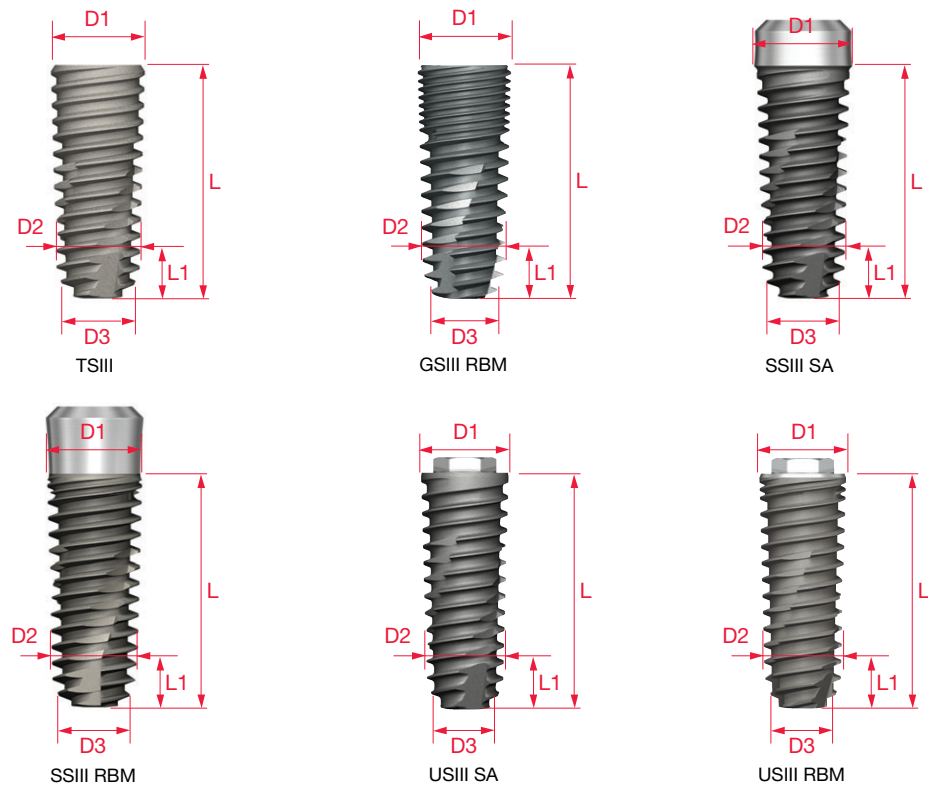

(Unit : mm)

	L	D1	D2	D3	L1
Fixture 3.5	8.5	3.8	3.4	2.5	1.3
	10.0	3.8	3.3	2.5	1.3
	11.5	3.8	3.2	2.5	1.3
	13.0	3.8	3.2	2.5	1.3
	15.0	3.8	3.1	2.5	1.3
Fixture 4.0	7.0	4.3	4.0	2.8	1.0
	8.5	4.3	3.9	2.8	1.3
	10.0	4.2	3.8	2.8	1.3
	11.5	4.2	3.7	2.8	1.3
	13.0	4.2	3.7	3.1	4.0
Fixture 4.5	7.0	4.7	4.4	3.1	1.0
	8.5	4.6	4.3	3.1	1.3
	10.0	4.6	4.2	3.1	1.3
	11.5	4.6	4.1	3.1	1.3
	13.0	4.6	4.1	3.5	4.0
Fixture 5.0	6.0	5.1	4.9	3.7	1.0
	7.0	5.1	4.9	3.7	1.0
	8.5	5.1	4.8	3.7	1.3
	10.0	5.1	4.8	3.7	1.3
	11.5	5.1	4.7	3.7	1.3
	13.0	5.1	4.8	4.0	4.0

(Unit : mm)

	L	D1	D2	D3	L1
Fixture 3.5	8.5	3.5	3.5	2.6	2.0
	10.0	3.5	3.5	2.6	2.5
	11.5	3.5	3.5	2.6	2.5
	13.0	3.5	3.5	2.6	2.5
	15.0	3.5	3.5	2.6	2.5
Fixture 4.0 (USII SA)	7.0	4.2	4.1	2.9	1.5
	8.5	4.2	4.1	2.9	2.0
	10.0	4.2	4.1	2.9	2.5
	11.5	4.2	4.1	2.9	2.5
	13.0	4.2	4.1	2.9	2.5
Fixture 4.0 (TSII SA)	7.0	4.2	4.2	2.9	1.5
	8.5	4.2	4.2	2.9	2.0
	10.0	4.2	4.2	2.9	2.5
	11.5	4.2	4.2	2.9	2.5
	13.0	4.2	4.2	2.9	2.5
Fixture 4.5	7.0	4.4	4.4	3.1	1.5
	8.5	4.4	4.4	3.1	2.0
	10.0	4.4	4.4	3.1	2.5
	11.5	4.4	4.4	3.1	3.0
	13.0	4.4	4.4	3.1	3.0
Fixture 5.0	6.0	5.0	5.0	4.3	0.5
	7.0	4.9	4.9	3.3	2.0
	8.5	4.9	4.9	3.3	2.0
	10.0	4.9	4.9	3.3	2.5
	11.5	4.9	4.9	3.3	3.0
	13.0	4.9	4.9	3.3	3.0

# Actual Dimensions of SSII SA

## SSII SA Fixture

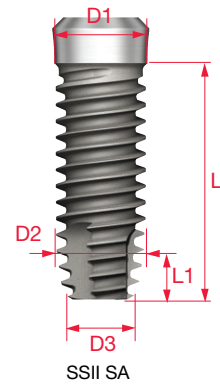

(Unit : mm)

	L	D1	D2	D3	L1
Fixture 4.0	7.0	4.1	4.1	3.3	1.5
	8.5	4.1	4.1	3.3	2.0
	10.0	4.1	4.1	3.3	2.5
	11.5	4.1	4.1	3.3	2.5
	13.0	4.1	4.1	3.3	2.5
	15.0	4.1	4.1	3.3	2.5
Fixture 4.5	L	D1	D2	D3	L1
	7.0	4.4	4.4	3.7	1.5
	8.5	4.4	4.4	3.7	2.0
	10.0	4.4	4.4	3.7	2.5
	11.5	4.4	4.4	3.7	2.5
	13.0	4.4	4.4	3.7	2.5
Fixture 5.0	L	D1	D2	D3	L1
	6.0	5.0	5.0	4.2	1.5
	7.0	4.9	4.9	4.2	1.5
	8.5	4.9	4.9	4.2	2.0
	10.0	4.9	4.9	4.2	2.5
	11.5	4.9	4.9	4.2	2.5
13.0	4.9	4.9	4.2	2.5	
15.0	4.9	4.9	4.2	2.5	

# Actual Dimensions of TSIV

## TSIV Fixture

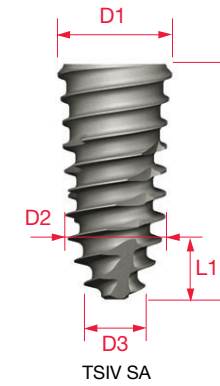

(Unit : mm)

	L	D1	D2	D3	L1
Fixture 4.0	7.0	4.45	3.8	1.8	2
	8.5	4.45	3.9	1.8	3
	10.0	4.45	4.0	1.8	4
	11.5	4.45	4.0	1.8	5
	13.0	4.45	4.0	1.8	6
	Fixture 4.5	L	D1	D2	D3
7.0		4.85	4.0	2.0	2
8.5		4.85	4.2	2.0	3
10.0		4.85	4.3	2.0	4
11.5		4.85	4.3	2.0	5
13.0		4.85	4.3	2.0	6
Fixture 5.0	L	D1	D2	D3	L1
	7.0	5.3	4.3	2.2	2
	8.5	5.3	4.6	2.2	3
	10.0	5.3	4.7	2.2	4
	11.5	5.3	4.7	2.2	5
	13.0	5.3	4.6	2.2	6

# Actual Dimensions of GSII RBM

# Actual Dimensions of SSII RBM

## GSII RBM Fixture | SSII RBM Fixture

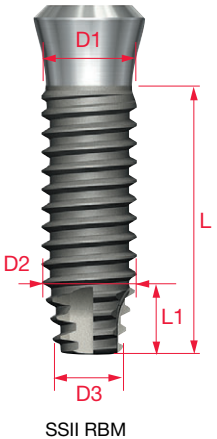
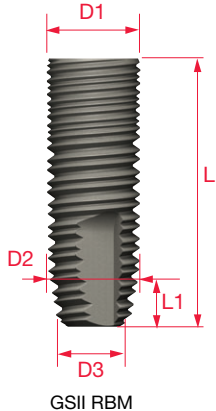

(Unit : mm)

	L	D1	D2	D3	L1
Fixture 3.5	8.5	3.5	3.5	3.0	1.3
	10.0	3.5	3.5	3.0	2.4
	11.5	3.5	3.5	3.0	2.4
	13.0	3.5	3.5	3.0	2.4
	15.0	3.5	3.5	3.0	2.4
Fixture 4.0	7.0	4.0	4.0	3.2	1.3
	8.5	4.0	4.0	3.2	1.3
	10.0	4.0	4.0	3.2	2.4
	11.5	4.0	4.0	3.2	2.4
	13.0	4.0	4.0	3.2	2.4
	15.0	4.0	4.0	3.2	2.4
Fixture 4.5	7.0	4.4	4.4	3.7	1.3
	8.5	4.4	4.4	3.7	1.3
	10.0	4.4	4.4	3.7	2.4
	11.5	4.4	4.4	3.7	2.4
	13.0	4.4	4.4	3.7	2.4
	15.0	4.4	4.4	3.7	2.4
Fixture 5.0	7.0	4.9	4.9	4.1	1.3
	8.5	4.9	4.9	4.1	1.3
	10.0	4.9	4.9	4.1	2.4
	11.5	4.9	4.9	4.1	2.4
	13.0	4.9	4.9	4.1	2.4
	15.0	4.9	4.9	4.1	2.4

(Unit : mm)

	L	D1	D2	D3	L1
Mini P3.5 / ø3.3	8.5	3.3	3.3	2.7	2.5
	10.0	3.3	3.3	2.7	2.5
	11.5	3.3	3.3	2.7	2.5
	13.0	3.3	3.3	2.7	2.5
	15.0	3.3	3.3	2.7	2.5
Regular P4.8 / ø4.1	7.0	4.1	4.1	2.9	2.2
	8.5	4.1	4.1	2.9	2.2
	10.0	4.1	4.1	3.2	3.0
	11.5	4.1	4.1	3.2	3.0
	13.0	4.1	4.1	3.2	3.0
	15.0	4.1	4.1	3.2	3.0
Regular P4.8 / ø4.8	7.0	4.8	4.8	3.9	2.2
	8.5	4.8	4.8	3.9	3.0
	10.0	4.8	4.8	3.9	3.0
	11.5	4.8	4.8	3.9	3.0
	13.0	4.8	4.8	3.9	3.0
	15.0	4.8	4.8	3.9	3.0
Wide P6.0 / ø4.8	7.0	4.8	4.8	4.0	2.2
	8.5	4.8	4.8	4.0	2.2
	10.0	4.8	4.8	3.9	3.0
	11.5	4.8	4.8	3.9	3.0
	13.0	4.8	4.8	3.9	3.0
	15.0	4.8	4.8	3.9	3.0

# Actual Dimensions of USII RBM

# Actual Dimensions of GSII / SSII / USII RBM Ultra-Wide®

## USII RBM Fixture

## GSII / SSII / USII RBM Ultra-Wide® Fixture

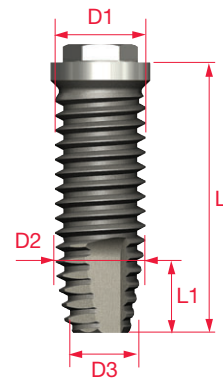

USII RBM

(Unit : mm)

	L	D1	D2	D3	L1
Mini P3.5 / ø2.4	8.1	3.3	3.3	2.0	2.0
	9.6	3.3	3.3	2.5	2.0
	11.1	3.3	3.3	2.5	2.0
	12.6	3.3	3.3	2.5	2.0
	14.6	3.3	3.3	2.5	2.0
Regular P4.1 / ø3.75	6.6	3.7	3.7	2.3	2.0
	8.1	3.7	3.7	2.3	2.0
	9.6	3.7	3.7	2.3	2.5
	11.1	3.7	3.7	2.3	2.5
	12.6	3.7	3.7	2.3	2.5
Regular P4.1 / ø4.0	6.6	4.0	4.0	2.5	2.0
	8.1	4.0	4.0	2.5	2.0
	9.6	4.0	4.0	2.5	2.5
	11.1	4.0	4.0	2.5	2.5
	12.6	4.0	4.0	2.5	2.5
Wide P5.1 / ø5.0	6.6	5.0	5.0	3.3	2.0
	8.1	5.0	5.0	3.3	2.0
	9.6	5.0	5.0	3.0	2.5
	11.1	5.0	5.0	3.0	2.5
	12.6	5.0	5.0	3.0	2.5
Wide P5.1 / ø5.5	6.6	5.5	5.5	3.6	2.0
	8.1	5.5	5.5	3.6	2.0
	9.6	5.5	5.5	3.3	2.5
	11.1	5.5	5.5	3.3	2.5
	12.6	5.5	5.5	3.3	2.5
14.6	5.5	5.5	3.3	2.5	

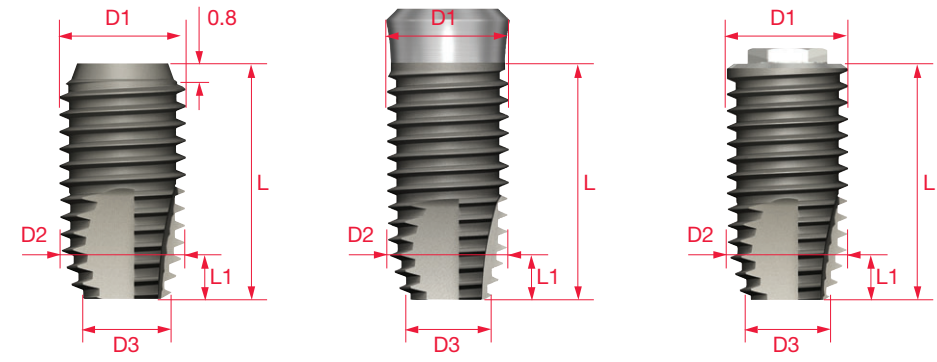

GSII Ultra

SSII Ultra

USII Ultra

(Unit : mm)

	L	D1	D2	D3	L1
Fixture 6.0	6.0	5.9	5.9	4.8	1.5
	7.0	5.9	5.9	4.8	1.5
	8.5	5.9	5.9	4.7	2
	10.0	5.9	5.9	4.7	2
	11.5	5.9	5.9	4.7	2.5
	13.0	5.9	5.9	4.7	2.5
Fixture 7.0	6.0	6.9	6.9	5.8	1.5
	7.0	6.9	6.9	5.8	1.5
	8.5	6.9	6.9	5.7	2
	10.0	6.9	6.9	5.7	2
	11.5	6.9	6.9	5.7	2.5
	13.0	6.9	6.9	5.7	2.5

※ SSII Ultra-wide : exception 6mm

# Actual Dimensions of TSIII SA Ultra-Wide®

## TSII SA Ultra-Wide® Fixture

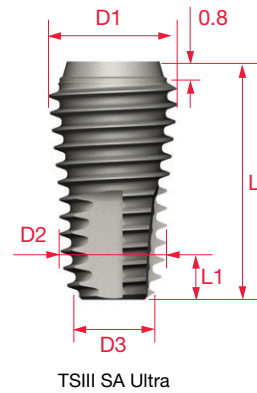

(Unit : mm)

	L	D1	D2	D3	L1
Fixture 6.0	6.0	6	5.5	4.5	1.4
	7.0	6	5.2	4.3	1.5
	8.5	6	5.1	4.2	2
	10.0	6	5.1	4.2	2.8
	11.5	5.9	5.0	4.2	3.3
	13.0	5.9	5.0	4.2	4.5
Fixture 7.0	6.0	6.8	6.4	5.4	1.4
	7.0	6.8	6	5.2	1.5
	8.5	6.8	5.9	5.1	2.5
	10.0	6.8	5.8	5.1	3
	11.5	6.8	5.7	5.0	4
	13.0	6.8	5.7	4.9	5

KIT