

NT-580A

Weighing Indicator

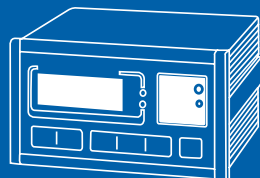

www.globalcas.com

OWNERS MANUAL

CAS

1. Introduction

We greatly appreciate for your purchase of the CAS industrial indicator. These goods have hold excellent performance and splendid properties through strike Tests as well as devoting ourselves under severe quality management.



CAS indicator (NT-series) is shaped firmly and delicately designed a coincide with the special requirements of several industrial fields and includes many functions and various external interfaces. Also, it is programmed on the basic of the user's convenience and contains help display functions to be used easily.

Before using NT-580A, It is recommended to read this manual carefully and to apply the function application fully.



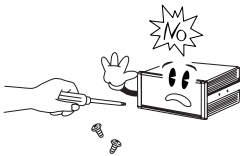
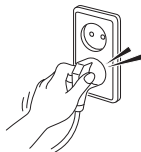

Precautions

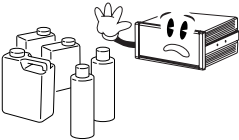
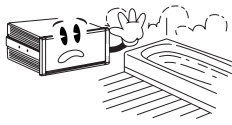
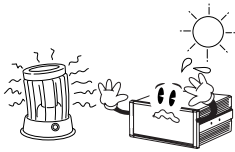
Observe the following safety precautions :

Warning

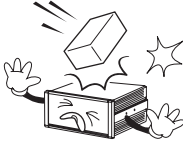
<p>When any damage or defect occurs, contact your CAS authorized dealer immediately for proper repair.</p>	<p>Insert plug firmly to wall outlet to prevent electric shock.</p>	<p>Scale must be grounded to minimize electricity static. This will minimize defect or electric shock.</p>
		
<p>Do not pull the plug by its cord when unplugging. Damaged cord could cause electric shock or fire.</p>	<p>To prevent from fire occurring, Do not place or use the scale near flammable or corrosive gas.</p>	<p>To reduce electric shock or incorrect reading, Do not spill water on the scale or place it in humid condition.</p>
		
<p>Avoid placing the scale near heater or in direct sunlight.</p>		
		

! Attention

<p>For consistent and accurate reading, maintain periodical check by your CAS authorized dealer.</p>	<p>Avoid sudden shock to the scale. Internal mechanism could be damaged.</p>	<p>Attach the rubber pad to the bottom of the indicator. Elimination is possible.</p>
		
<p>Place the scale on firm and temperature consistent environment.</p>	<p>Keep the scale away from other electromagnetic generation devices. This may interfere with accurate reading.</p>	
		

Our Dealers : CAS feels that each of its valued customers should get the best service available. Whether it's the initial installation of our product, maintenance/repair work, or simply answering questions about our products, CAS Corporation and all of its Authorized Dealers are highly trained to assist you with any need regarding CAS products.

Table of Contents

1. Features	10
1-1. Features	10
1-2. Main function	10
1-3. Analog Part & A/D Conversion	11
1-4. Digital Part	11
1-5. General Specification	12
1-6. Option Specification	12
2. Measure of Appearance	13
2-1. Measure of Appearance	13
2-2. Front Panel	14
2-3. Rear Panel	18
3. Installation & Connection	19
3-1. Loadcell connection	19
4. Calibration Mode	20
4-1. How to enter Calibration Mode	20
4-2. Available key in the Calibration Mode	20
4-3. Calibration Menu	20
- Maximum Value Set	21
- Setting Minimum division and Dot position	21
- Setting Multi Calibration Range	22
- Zero Calibration	22
- Setting Weight value	23
- Weight Calibration	23
- Zero Adjust	24
- Weight Constant Calibration	24
4-4. Sealing Method	25

5. Set Mode 26

5-1. How to enter Set Mode	26
5-2. Available key in Calibration Mode	26
5-3. Menu of Set Menu(F01 ~ F99)	27
5-3-1. General function	30
5-3-2. Serial interface	33
5-3-3. Print function	37
5-3-4. Batching Operation Function.....	41
5-3-5. Option Function.....	43
5-3-6. Input set point	44
5-3-7. Initialize set Mode Value	44

6. Test Mode 45

6-1. Method of enter the Test Mode	45
6-2. Explain key in the Test Mode	45
6-3. Test Menu	46
- Key Test	46
- Display Test	46
- A/D Test	47
- RS232(Serial) Test	47
- Print Test	48
- External In/Out Test	48
- BCD out(Optional) Test	49
- Analog out (Option) Test	49
- BCD In(Optional) Test	50
- RTC Test	50

7. Weighing Mode	51
7-1. Method of enter the Weighing Mode.....	51
7-2. Explain key in the Weighing Mode	51
7-3. External In/Out control Interface	53
7-4. Item Code	55
7-5. Set Point Input.....	56
7-6. Regulation of Input Set Point	57
7-7. Batching Operation	58
User Program Control Mode	58
- Normal Batching.....	60
- Loss-in- Weight Batching.....	62
Automatic Program Control Mode.....	58
- Normal Batching.....	64
- Loss-in- Weight Batching.....	66
8. Serial Communication	68
8-1. RS-232C Connection.....	68
8-2. Serial communication device connection.....	69
8-2-1. Sub display connection	69
8-2-2. CAS TOP printer connection	69
8-2-3. CP-7000 Series printer connection	69
8-3. RS-232C PROTOCOL.....	70
8-3-1. 22 Bytes of CAS.....	70
8-3-2. 10 Bytes of CAS.....	71
8-3-3. 18 Bytes of AND	71
8-4. Simple Interface Program.....	72

9.OPTION	73
9-1. Current Loop Serial Out	73
9-2. RS-485 Serial Interface	74
9-3. BCD Out Interface	75
9-4. Analog Out Interface(4~20mA)	77
9-5. Analog Out Interface(0~10V)	80
9-6. BCD IN Interface	82
10. Error Message	84
10-1. Error Message in the Calibration Mode	84
10-2. Error Message in the Weighing Mode	85

1. Features

1-1. Features

- High speed, High accuracy
- High speed micro processor adoption
- A/D conversion speed : Maximum 200 times/sec
- Appropriate for weight and measurement system
- Easy operation and various options.
- Simple and prompt Full Digital Calibration (SPAC™: Single pass automatic span Calibration)
- RFI/EMI screened
- Watch Dog circuitry (System restoration)
- Weight Back-up (Weight memory at sudden power failure)

1-2. Main Functions

- Store date, time and calculated data at sudden power failure.
- Various specification on weight conversion speed. (Digital filter function)
- Various printer connection. (RS-232C Serial printer)
- Tare weight setting with keys.
- Storage of measured times.
- Set Point input & highest, lowest limit input.
- External input 6 relay.
- External output 8 relay.
- Users can set the desirous max. weight and a division freely.
- Control various external equipment by inner external input/output.
- Print date and time by inner clock.
- Self hardware Test.
- Prompt A/S is available for Test of each part of circuit by module is possible.

1-3. Analog Part & A/D Conversion

Load Cell Excitation Voltage	DC 10V, 8 x 350Ω load cells
Zero Adjustment Range	0.05mV ~ 20mV
Input Sensitivity	1.2μV/D (H-44,OIML) 0.6μV/D (Non H-44,OIML)
System Linearity	Within 0.01% of F.S.
A/D Internal Resolution	1 / 200,000
A/D External Resolution	1/5,000 (H-44,OIML) 1/20,000 (Non H-44, OIML)
A/D Conversion Speed	Maximum 200 times/sec

1-4. Digital Part

Span Calibration	Full Digital Calibration : SPAC™ (Single automatic span Calibration)
Display	VFD 7Digit
Size of letter	13 mm (Height)
Division	×1, ×2, ×5, ×10, ×20, ×50
Tare Subtraction	Full capacity
Display Below Zero	“-”Minus

1-5. General Specification

Power	AC 85~264V, 50~60 Hz
Product Size	192(W) x 199(D) x 96 (H)
Temperature Range	-10°C ~ 40°C
Fuse Capacity	T2A L250V
Product Weight	Approx. 1.8 kg

1-6. Option Specification

Option - 1	Serial Interface : Current Loop
Option - 2	Serial Interface : RS-485
Option - 3	BCD OUT
Option - 4	Analog OUT (Iout : 4 - 20mA)
Option - 5	Analog OUT (Vout : 0 - 10V)
Option - 6	BCD IN(Input of Set Point)

2. Measure of Appearance

2-1. Measure of Appearance

Unit : mm

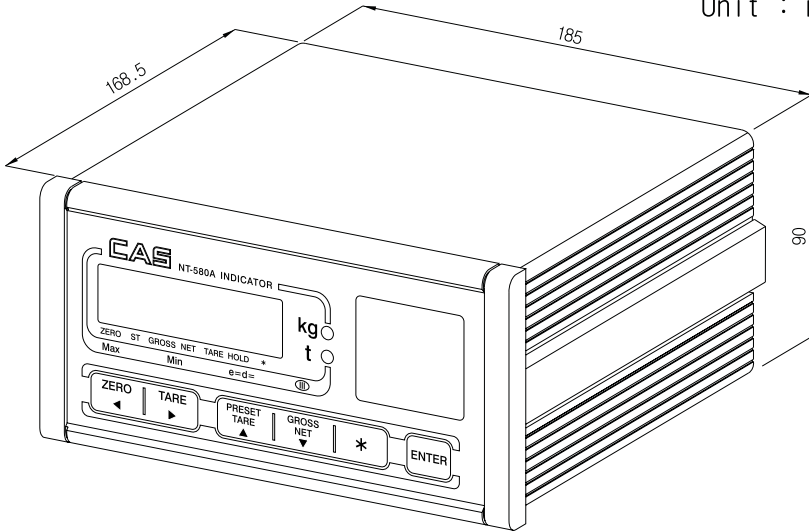

Unit : mm

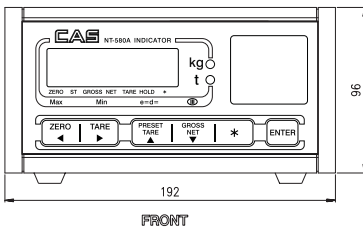

FRONT

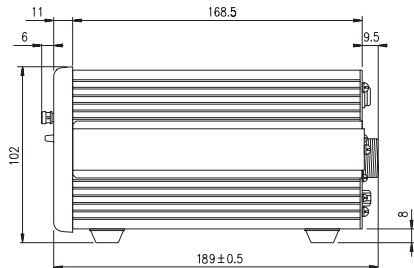

SIDE

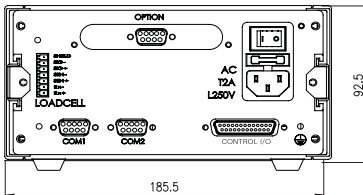

REAR



INSERT PANEL SIZE

2-2. Front Panel

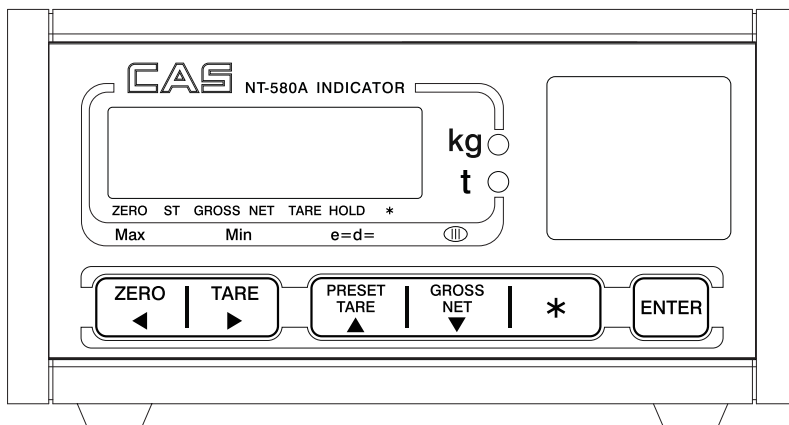

(1) Main Display (weight)

- A. Weight value display
 - Displays the Gross weight or the Net weight
 - When error occurred, the display shows error and weight value alternately.
- B. Over scale and error display
 - Over-scale, sequence errors and Calibration errors are displayed
 - ※ Please refer to “ Error Message “ on P.94
- C. Setting value display
 - Various final discharge setting values and setting values for adjustment are displayed.

(2) Status Display

"Zero" Lamp	▼	Current weight is 0 kg
"ST" Lamp	▼	Weight is stable.
"Gross" Lamp	▼	Current weight is Gross weight
"Net" Lamp	▼	Current weight is Net weight
"Tare" Lamp	▼	Tare is stored
"Hold" Lamp	▼	Lamp is on when moving object is weighed.
"*" Lamp	▼	Lamp is on when "*" key is used. (Designate in the Set Mode F42) automatic Print is set

(3) Keyboard



- ▲, ▼, ◀, ▶ Key : Available keys instead of numeric keys
 - ▲, ▼ : Change the set value.
▲ key increases the set value and ▼ key decreases the set value.
 - ◀, ▶ : Change the digit of the set value.
▶ key moves one digit to right, ◀ key moves one digit to left.
 - USAGE 1: Input the tare weight.
 - USAGE 2: Input the Set Point value.
 - USAGE 3: Input the numeral value in the Test, CAL, SET Mode.
- ZERO Key : Return the display to 0.
- TARE Key (Automatic tare weight input)
 - Use a container in weighing.
Current weight is memorized as the tare weight.
 - If you press the TARE key in the unload condition, the tare setting is released.
- KEY TARE Key (Manual tare weight input)
When you already know the tare weight, press the KEY TARE key and input the tare weight with arrow keys and memorize it by pressing the ENTER key.

- G/N Key (Gross/Net key)
 - Display the gross and net weight by turn.
 - G weight lamp on - gross weight.
 - N. weight lamp on - net weight.
 - In case the tare weight is registered, the total weight of tare and item is the G weight and only the weight of item is N. weight.
 - To use or To prohibit the Front keys.
 - (The program is converted by pressing G/N key more than 4 sec.)
- “*” Key
 - “*” key is used in various ways.
 - Set the Set Point value for the batching operation.
 - (The program is converted by pressing * key for more than 2 sec.)
 - It is used as the function designated in the SET Mode F17.
 - 0. Do not use.
 - 1. PRINT Key.
 - 2. HOLD Key.
- ENTER Key
 - ENTER key is used in various ways.
 - Set the Set Point "CODE" for the batching operation.(00~49)
 - (The program is converted by pressing the ENTER key for more than 2 sec.)
 - It is used as the function designated in the SET Mode F18.
 - 0. Do not use.
 - 1. Total print key.
 - 2. Start key for the batching operation.
 - 3. Stop key for the batching operation.
 - In the CALIBRATION, Test, SET Mode : Store current a condition and exit.

(4) Front slide S/W usage

If you open the front cover of the indicator, you will see the Dip switch.
You can enter the related Mode to the state of the SW.

□ DIP Switch : Mode Table

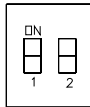

DIP S/W		Mode
0	0	Test Mode (TEST)
0	1	Calibration Mode (CAL)
1	0	Set Mode (SET)
1	1	Weighing Mode (WEIGHING)

□ Test Mode

- If you turn off all of the DIP switches(0,0), you can move into the Test Mode then.
- If you turn on all of the DIP switches(1.1) after the Test, you can return to the Weighing Mode then.

□ Calibration Mode

- If you turn on only the DIP switch 1 (0, 1), you can move into the Calibration Mode then.
- If you turn on all of the DIP switches (1,1) after the Calibration, you can return to the Weighing Mode then..

□ Set Mode

- If you turn on only the DIP switch 2(1, 0), you can move into the Set Mode then.
- If you turn on all of the DIP switches(1,1) after the Calibration, you can return to the Weighing Mode then.

2-3. Rear Panel

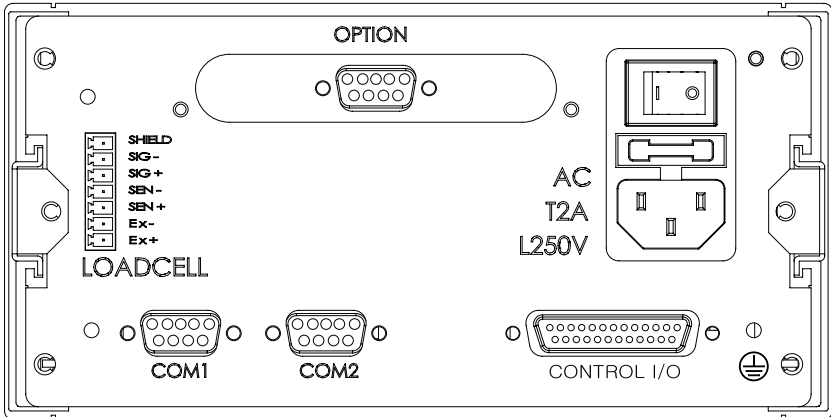

- **LOAD CELL** : Port for connection. 4Wires, 6Wires Loadcell
- **COM 1** : Serial Interface Com Port (Option - RS485)
- **COM 2** : Serial Interface Com Port
- **Control I/O**
 - External Input : Zero, Tare, Start, Stop , *, Enter key.
 - External Output : External Output for Batching operation.
- **OPTION** : When Option in Use, please connect.
- **AC INPUT** : AC 100 ~ 240V(50/60Hz) ara available.
FUSE - T2A L250V

3. Installation & Connection

3-1. Loadcell Connection

Connect the load cell connector to the load cell port which is in the backside of the indicator.

* Connection method

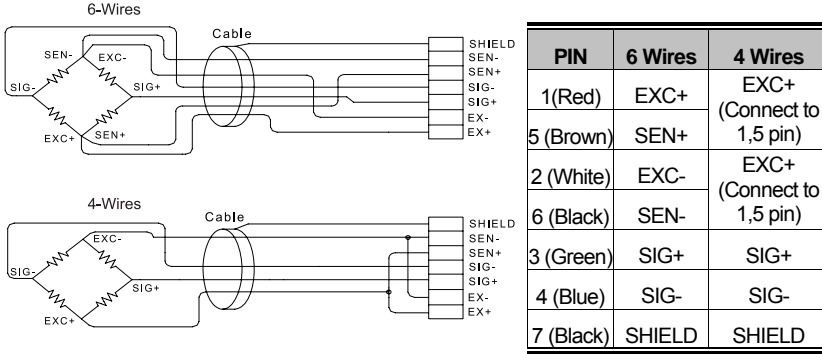

Note . In case of the 4 wires load cell, connect EX+ with SEN+, and connect EX- with SEN-.

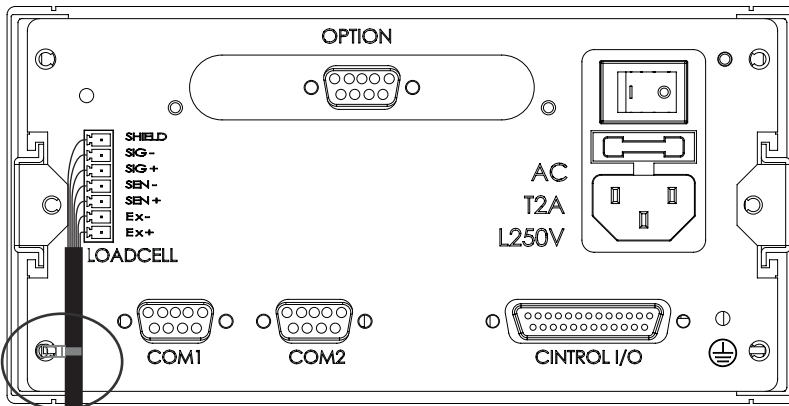

Note . Fix a loadcell wire as above picture by using cable tie.

4. Calibration Mode

4-1. How to enter Calibration Mode

If you open the front cover of the indicator and turn on the DIP S/W2, the Calibration Mode is started.

At this time, CAL message is displayed on VFD and CAL 1 runs automatically.

If you turn on all of the DIP switches(1,1) after the Calibration, you can return to the Weighing Mode then.

4-2. Available Keys in Calibration Mode

▲, ▼ Key : Change the set value

▲ Key : increase set value

▼ Key : decrease set value

▶, ◀ Key : Change the digit of set value

▶ Key : moves one digit to right

◀ Key : moves one digit to left

”*” Key : Cancel of input value

ENTER Key : The program is moved into the next menu after saving the set value.

4-3. Calibration Menu(CAL1 ~ CAL9)

CAL 1 : Maximum Value Set

CAL 2 : Minimum Division & Dot Position Set

CAL 3 : Weight Calibration

3-1. Set Range of Multi Calibration

3-2. Zero Calibration

3-3. Set Weight

3-4. Span Calibration

CAL 8 : Zero Adjust

CAL 9 : Weight Constant Calibration

CAL 1 (CAL 1 Start automatically)

Function : Maximum Capacity(range: 1 ~ 99,999)		
KEY	VFD SCREEN	DESCRIPTION
▲,▼ : increase or decrease of no. ►,◄ : Shift of digit ** " : Cancel and move to CAL-1 Enter : Store and move Into next menu	C = 10	Maximum capacity is 10
	C = 100	Maximum capacity is 100
	C = 1000	Maximum capacity is 1000
	C = 10000	Maximum capacity is 10000

Ref 1. The maximum value means the maximum weight that a scale can measure.

CAL 2

Function : Setting Minimum division and Dot position Setting value range : 0.001 ~ 50		
USED KEY	VFD SCREEN	DESCRIPTION
▲,▼ : increase or decrease of no. ►,◄ : Shift of digit ** " : Cancel and move to CAL-1 Enter : Store and move into next menu	div = 0.001	Minimum division : 0.001 kg
	div = 0.01	Minimum division : 0.01kg
	div = 0.1	Minimum division : 0.1 kg
	div = 1	Minimum division : 1kg

Ref 1. Minimum division means minimum change(one division value) of unit of weighing change.

Ref 2. External resolution is the value dividing maximum weight into minimum division, and its setting range should be less than 1/10,000.

Ref 3. Dot position is decided by dot position of minimum division set in CAL2 mode.

CAL 3

CAL 3-1

Function : Setting Multi Calibration Range Setting value range : 1 ~ 5		
USED KEY	VFD SCREEN	DESCRIPTION
▲, ▼ : increase or decrease of no. ►, ◀ : Shift of digit ** * : Cancel and move to CAL-1 Enter : Store and move into next menu	STEP- 1	Setting 1 step multi calibration (perform CAL3-3, CAL 3-4 once)
	STEP- 3	Setting 3 step multi calibration (perform CAL3-3, CAL 3-4 three times)
	STEP- 5	Setting 5step multi calibration (perform CAL3-3, CAL 3-4 five times)

CAL 3-2

Function : Zero Calibration		
USED KEY	VFD SCREEN	DESCRIPTION
** * : Cancel and move to CAL-1 Enter : Store and move into next menu	UnLoAd	Empty load receptor and press "ENTER" key.
	1234	Present weighing value is displayed. Check stability, press "ENTER" key.
	---	In the setting zero calibration..

Ref 1. After setting zero calibration without errors, it is going to automatically move to CAL 3-3 without pressing any key

Ref 2. If zero is too low, error message "Err 27" will be displayed.

Ref 3. If zero is too high, error message "Err 26" will be displayed.

CAL 3-3

Function : Setting Weight value Setting value range : 1 ~ 99,999		
USED KEY	VFD SCREEN	DESCRIPTION
▲,▼ : increase or decrease of no. ►,◄ : Shift of digit ** " : Cancel and move to CAL-1 Enter : Store and move into next menu	LOAD 1	It means setting weight value mode. (number = multi calibration number)
	W=100.00	100.00 (Unit : Kg or Ton)
	W= 0.10	0.10 (Unit : Kg or Ton)

Ref1. Set the weight value within 10% ~ 100% range of maximum weight.

At the beginning, it has been automatically set 100% of maximum weight.

If the actual weight value is different from minimum weight, reenter the weight value which you have.

(If weight value exceeds maximum weight, error message "Err 23" will be displayed.

If weight value is below 10% of maximum weight, error message "Err 20" will be displayed, and the accuracy will be decreased under 10%.)

CAL 3-4

Function : Weight Calibration		
USED KEY	VFD SCREEN	DESCRIPTION
** " : Cancel and move to CAL-1 Enter : Store and move into next menu	LoAd	Load the weight that you set in CAL3-3 on load receptor and press "ENTER" key.
	12345	Present weighing value is displayed.
	---	Check stability, press "ENTER" key. In the setting span.

Ref 1. Perform repeatedly CAL3-3, CAL3-4 as the number of times as you set step in CAL3-1.

At this time, weight value should be set as higher value than previous value.

Ref2. If setting span is complete without errors, move to CAL-1.

Ref3. If span value is low, error message "Err 24" will be displayed.

Ref 4. If span value is high, error message "Err 25" will be displayed.

CAL 8

Function : Zero Adjust		
KEY	VFD SCREEN	DESCRIPTION
** " : Cancel and move to CAL-1 Enter : Store and move into next menu	2-CAL	Unload the tray and press the Enter Key
	1234	Current A/D Value displayed Check the stable and press the Enter Key.
	- - -	Under Zero Calibration

Ref 1. Use it that the initial zero range can not be passed because the load cell is damaged

Ref2. If the zero Calibration is done without any error, the program moves into CAL-1 automatically.

Ref 3. If the zero value is too low, the error message "Err 26" is displayed.

Ref 4. If the zero value is too high, the error message "Err 27" is displayed.

CAL 9

Function : Weight Constant Calibration		
KEY	VFD SCREEN	DESCRIPTION
▲,▼ : increase or decrease of no. ►,◄ : Shift of digit ** " : Cancel and move to CAL-1 Enter : Store and move into next menu	NOT USE	You can use this function because of the Multi-Calibration.
	FAcTor	It means the weight constant calibration Mode
	12345	Current Factor Value displayed

Ref 1. The ordinary user doesn't need to use this menu because it is used for the Calibration without a weight.

Ref2. It is available only when setting the range of the multi-Calibration to 1.

When setting the range of CAL4-1 over 2, "NOT USE" is displayed.

Ref3. If you want to enter the weight constant calibration Mode, you must input the password then.

4-4. Sealing Method

Sealing Method of front cal switch.

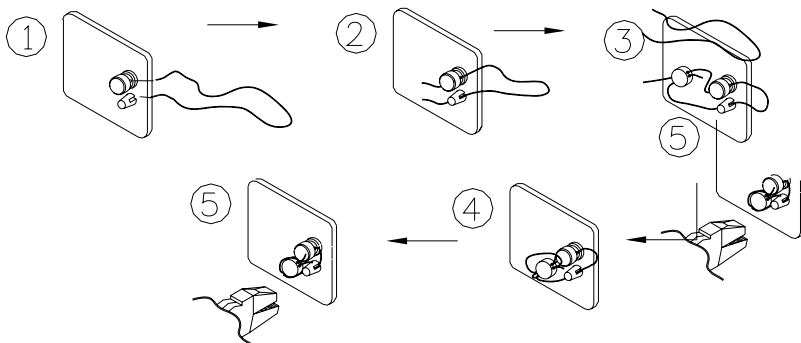
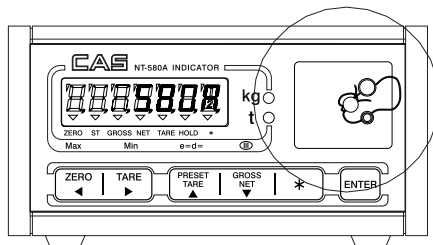

5. Set Mode

5-1. How to enter Set Mode

If you open the front cover of indicator and turn on the DIPS/W1, the Calibration Mode is started.

At this time, SET message is displayed on VFD and F 01 runs automatically.

If you turn on all of the DIP switches(1,1) after the Calibration, you can return to the Weighing mode then.

1. F 01 : Call the function which you want to convert.
2. Input function no. to convert with arrow keys and press the ENTER key.
3. F01 1 : It means call the function which you would convert.
4. Input function no. to convert and press the ENTER key.

5-2. Available Keys in Calibration Mode

▲, ▼ Key : Change the set value

▲ Key : increase the set value

▼ Key : decrease the set value

▶, ◀ Key : Change the digit of the set value

▶ Key : moves one digit to right

◀ Key : moves one digit to left

”*” Key : Cancel of input value

ENTER Key : The program is moved into the next menu

5-3. Menu of Set Mode (F01 ~ F99)

General function		
F01	-	Date Change
F02	-	Time Change
F04	(10)	A/D Converting Speed
F05	(10)	Digital Filter
F07	(02)	Motion Detection Condition
F08	(02)	Automatic Zero Tracking Compensation
F09	(00)	Weight Backup
F10	(00)	Set Hold Type
F13	(10)	Set Zero Range
F14	(01)	ZERO, TARE & START Keys Availability)
F17	(00)	Designation of "*" key usage
F18	(00)	Designation of "Enter" key usage
F19	(00)	Weighing Unit Change
F20	(00)	Loadcell type Selection
F21	(10)	Initial Zero Range
F23	(09)	Overload Range

Serial Interface		
F26	(00)	Device ID
F27	(00)	Parity Bit Set
F28	(04)	Baud Rate Set of COM1
F29	(00)	COM1 Usage
F30	(00)	COM1 Output Format
F31	(00)	COM1 Output Mode
F32	(04)	Baud Rate Set of COM2
F33	(01)	COM2 Usage
F34	(00)	COM2 Output Format
F35	(00)	COM2 Output Mode
Print function		
F40	(02)	Designation of Printer
F41	(00)	Designation of Printing Format
F42	(00)	Automatic Print / Manual Print
F43	(01)	Designation of Line Feed
F44	-	Input User's Information to Printing Format
F45	(01)	Set Operation of Printer

*Ref. The number in () is the initial value in a factory shipment.

Batching operation function		
F50	(00)	Measurement Mode
F53	(10)	Start Delay Time
F54	(10)	Finish Signal Start Delay Time
F55	(00)	Finish Signal Operating Delay Time
F56	(00)	Finish Signal OFF Range
Option function		
F66	(00)	Option Type - BCD Out (Option - 3) - Analog Out (Option - 4,5) (4~20mA : current, 0~10V : voltage) - Current Loop
F68	-	Current or Voltage Output Adjustment at Display Zero
F69	-	Current or Voltage Output Adjustment at Maximum Capacity
F72	(00)	Output Logic Designation (BCD Out)
F73	(00)	External Set Point Input

Input of Set Point		
F80	-	Set Point 1 - Zero Band
F81	-	Set Point 2 - Optional Preliminary Weight
F82	-	Set Point 3 - Preliminary Weight
F83	-	Set Point 4 - Final Weight
F84	-	Set Point 5 - Free Fall Weight
F85	-	Set Point 6 - High Limit Weight
F86	-	Set Point 7 - Low Limit Weight

SetMode Initial		
F99	-	Initialize the set value of the set Mode to the value in a factory shipment.

*Ref. The number in () is the initial value in a factory shipment.

5-3-1. General Function

F01

Function	Date Change	
Use Key ◀, ▶, ▲, ▼ : Change Data	VFD Display	DESCRIPTION
	02.01.10	JAN. 10TH, 2002

F02

Function	Time Change	
Use Key ◀, ▶, ▲, ▼ : Change Data	VFD Display	DESCRIPTION
	11.30.10	11:30:10 AM

F04

Function	A/D Converting Speed	
Set Value (00 ~ 99)	VFD Display	DESCRIPTION
	F04 10	20times/sec
	F04 50	100times/sec
	F04 99	198times/sec

F05

Function	Digital filter	
Set Value (00 ~ 50)	VFD Display	DESCRIPTION
	F05 10	10times average value display
	F05 30	30times average value display
	F05 50	50times average value display

Ref 1. Use the function of F05 by adjusting the set value according to an environment.

F07

Function	Motion Detection Condition	
Set Value (1 ~ 99)	VFD Display	DESCRIPTION
	F07 2	Stable lamp is on even with the change of only 2 division
	F07 10	Stable lamp is on even with the change of only 10 division
	F07 99	Stable lamp is on even with the change of only 99 division

F08

Function	Automatic Zero Tracking Compensation	
Set Value (0~9)	VFD Display	DESCRIPTION
	F08 0	Zero Tracking Function is off
	F08 1	If the value gradually changes under the 0.5, then Execute zero tracking compensation
	F08 2	If the value gradually changes under the 1.0, then Execute zero tracking compensation
F08 9	If the value gradually changes under the 4.5, then Execute zero tracking compensation	

Ref 1. It is the function that brings the display back to “0” when there are small deviations.

F09

Function	Weight Backup	
Set Value (0, 1)	VFD Display	DESCRIPTION
	F09 0	Weight Back up is off
	F09 1	Weight Back up is on

Ref 1. It is the function that memorizes the current weight at a sudden power cut or a power-off.

F10

Function	Set Hold Type	
Set Value (0~3)	VFD Display	DESCRIPTION
	F10 0	Average Hold : Compute the average weight of oscillating weights
	F10 1	Peak Hold : Compute the maximum weight of oscillating weights
	F10 2	Sampling Hold : Compute the instant weight of oscillating weights
F10 3	Automatic Hold: Automatically compute the maximum weight of oscillating weights.	

Ref 1. If you want to use “Hold” function, please set F17 =2

F13

Function	Set Zero Range	
Set Value (2~99)	VFD Display	DESCRIPTION
	F13 2	Zero key operation within 2% of MAX. weight
	F13 10	Zero key operation within 10% of MAX. weight

Ref 1. If you set the “F13” values over 10, that is causes damage the loadcell

F14

Function	ZERO, TARE & START Keys Availability	
Set Value (0, 1)	VFD Display	DESCRIPTION
	F14 0	Always work
	F14 1	Work when weight is stable

F17

Function	Designation of “*”key usage	
Set Value (0~2)	VFD Display	DESCRIPTION
	F17 0	Do not use
	F17 1	Print key
	F17 2	Hold Key

* Set only one of F29 and F33 to 0 when using the Print Key.

F18

Function	Designation of “Enter”key usage	
Set Value (0~3)	VFD Display	DESCRIPTION
	F18 0	Do not use
	F18 1	Total print key
	F18 2	Start key in Batching system
	F18 3	Stop key in Batching system

F19

Function	Weighing Unit Change	
Set Value (0, 1)	VFD Display	DESCRIPTION
	F19 0	Kilogram (kg)
	F19 1	Ton (t)

F20

Function	Select of Loadcell Type	
Set Value (0, 1)	VFD Display	DESCRIPTION
	F20 0	Compression and tension load cell (0mV ~+40mV)
	F20 1	Compression or tension load cell (-20mV ~+20mV)

F21

Function	Initial Zero Range	
Set Value (2~20)	VFD Display	DESCRIPTION
	F21 2	Set of Initial Zero Range within 2% of max weight
	F21 10	Set of Initial Zero Range within 10% of max weight

F23

Function	Overload Check	
Set Value (9~99)	VFD Display	DESCRIPTION
	F22 9	Weight value is over 9d of max capacity then ‘Overload’ displayed
	F22 99	Weight value is over 99d of max capacity then ‘Overload’ displayed

5-3-2. Serial Interface

F26

Function	Device ID		DESCRIPTION
Set Value (00~99)	VFD Display		
	F26	00	Device ID=00
	F26	99	Device ID=99

Ref 1 . It is used as the proper ID of the indicator in the Command Mode.

F27

Function	Set of Parity Bit (Parity Bit- COM1 & COM2)		
Set Value (0~2)	VFD Display		DESCRIPTION
	F27	0	Data bit 8, Stop bit 1, Parity bit : None
	F27	1	Data bit 7, Stop bit 1, Parity bit : even
	F27	2	Data bit 7, Stop bit 1, Parity bit : odd

Ref 1. The NT-580A supplies two serial interfaces(COM1, COM2).

F26 and F27 is applied to two serial interfaces in common.

Serial Interface of COM1 Function

F28

Function	Set Baud Rate of COM1	
	VFD Display	DESCRIPTION
Set Value (0~8)	F28 0	600 bps
	F28 1	1200 bps
	F28 2	2400 bps
	F28 3	4800 bps
	F28 4	9600 bps
	F28 5	19200 bps
	F28 6	38400 bps
	F28 7	57600 bps
	F28 8	115200 bps

F29

Function	Usage of COM1	
	VFD Display	DESCRIPTION
Set Value (0~1)	F29 0	Connection with printer
	F29 1	Connection with sub-display or computer

* F29=0 and F33=0 then "Err-Set" displayed, and the print is disconnected.

F30

Function	Output Format of COM1	
	VFD Display	DESCRIPTION
Set Value (0~2)	F30 0	22Bytes – CAS Format
	F30 1	10Bytes – CAS Format
	F30 2	18Bytes – AND Format

F31

Function	Output Mode of COM1	
	VFD Display	DESCRIPTION
Set Value (0~4)	F31 0	No data transmission
	F31 1	Transmit data in a state of stable & unstable (Stream Mode)
	F31 2	Transmit data only in stable condition (Transmit 1 time after load in stable condition)
	F31 3	Transmit data if you input Device ID * Device ID (F31) Input 1Byte (hex code) (Data Request Device ID : 1=0x01, 10=0x0A)
	F31 4	Transmit data only in command Mode

* If it is used as the print Mode, set F31 = 1.

Serial Interface of COM2 Function

F32

Function	Set Baud Rate of COM2	
Set Value (0~8)	VFD Display	DESCRIPTION
	F32 0	600 bps
	F32 1	1200 bps
	F32 2	2400 bps
	F32 3	4800 bps
	F32 4	9600 bps
	F32 5	19200 bps
	F32 6	38400 bps
	F32 7	57600 bps
F32 8	115200 bps	

F33

Function	Usage of COM2	
Set Value (0~1)	VFD Display	DESCRIPTION
	F33 0	Connection with printer
	F33 1	Connection with sub-display or computer

* F29=0 and F33=0 then "Err-Set" displayed. And the print is disconnected.

F34

Function	Output format of COM2	
Set Value (0~2)	VFD Display	DESCRIPTION
	F34 0	22Bytes – CAS Format
	F34 1	10Bytes – CAS Format
	F34 2	18Bytes – AND Format

F35

Function	Output Mode of COM2	
Set Value (0~2)	VFD Display	DESCRIPTION
	F35 0	No data transmission
	F35 1	Transmit data in a state of stable & unstable (Stream Mode)
	F35 2	Transmit data only in stable condition (Transmit 1 time after load in stable condition)

* If it is used as the Print Mode, set F35 = 1

Ref 1. Command Mode Table

Command data to NT-580A											Command description	NT-580A Respond	
0	1	2	3	4	5	6	7	8	9	10			11
D	ID	K	Z	CR	LF							ZERO key	
D	ID	K	T	CR	LF							TARE key	Return the received
D	ID	K	G	CR	LF							GROSS key	Return the received
D	ID	K	N	CR	LF							NET key	Return the received
D	ID	K	S	CR	LF							START key	Return the received
D	ID	K	P	CR	LF							STOP key	Return the received
D	ID	K	B	CR	LF							Print key	Return the received
D	ID	K	C	CR	LF							Total print key	Return the received
D	ID	K	W	CR	LF							Request weight data	Return the received
D	ID	H	T	CR	LF							Request set point value	Send Format 2
D	ID	H	C	0	0	0	0	0	CR	LF	Request pertinent set point value to Set code	Send Format2	
D	ID	H	Z	0	0	0	0	0	CR	LF	Zero band	Return the received	
D	ID	H	O	0	0	0	0	0	CR	LF	Optional preliminary weight	Return the received	
D	ID	H	P	0	0	0	0	0	CR	LF	Preliminary	Return the received	
D	ID	H	F	0	0	0	0	0	CR	LF	Final value	Return the received	
D	ID	H	R	0	0	0	0	0	CR	LF	Free fall value	Return the received	
D	ID	H	I	0	0	0	0	0	CR	LF	High limit value	Return the received	
D	ID	H	L	0	0	0	0	0	CR	LF	Low limit value	Return the received	
D	ID	H	E	0	0	0	0	0	CR	LF	Set point code(00-99)	Return the received	

(D, ID:00~99, CR : 0×13, LF: 0×10, Command HC, HE range=00~99)

*** Format 1 : PC send set point all data to indicator NT-580A**

0	1	2	3	4	5	6	7	8	9	10	11	12	13	14	15	16	17	18	19	
D	ID	H	A	Set point code						,	Zero Band						,	Optional-		
20	21	22	23	24	25	26	27	28	29	30	31	32	33	34	35	36	37	38	39	
Preli		,	Preliminary					,	Final value					,	Free Fall					
40	41	42	43	44	45	46	47	48	49	50	51	52	53							
,	High limit					,	Low limit					CR	LF							

*** Format 2 : Recieve the request data from PC then response of Indicator**

0	1	2	3	4	5	6	7	8	9	10	11	12	13	14	15	16	17	18	19	
D	ID	H	T	Set point code						,	Zero Band						,	Optional-		
20	21	22	23	24	25	26	27	28	29	30	31	32	33	34	35	36	37	38	39	
Preli		,	Preliminary					,	Final value					,	Free Fall					
40	41	42	43	44	45	46	47	48	49	50	51	52	53							
,	High limit					,	Low limit					CR	LF							

* Please input without the decimal point.

5-3-3. Print Function

F40

Function	Printer	
Set Value (0~2)	VFD Display	DESCRIPTION
	F40 0	Do not use
	F40 1	CAS TOP printer (P202)
	F40 2	CP-7000 Series Printer (CP-7000D/P, CP-7024P)

F41

Function	Printer Format	
Set Value (0~2)	VFD Display	DESCRIPTION
	F41 0	Print format 0
	F41 1	Print format 1
	F41 2	Print format 2

F42

Function	Automatic Print / Manual Print	
Set Value (0, 1)	VFD Display	DESCRIPTION
	F42 0	Manual print
	F42 1	Automatic print

Ref 1. . If the automatic print is set, printing is done without pressing the print key only when the weight condition is stable.

F43

Function	Line Feed	
Set Value (1~9)	VFD Display	DESCRIPTION
	F43 1	1 Line feed
	F43 9	9 Line feed

【 Print Format 0 】

Date, Time, Serial No, Net Weight

02. 1. 1	12:30
001,	50.0 kg
002,	100.0 kg
003,	200.5 kg

TOTAL	350.5 kg

【 Print Format 1 】

Date, Time, Serial No, Net Weight

02. 1. 1	12:30
001,	50.0 kg
02. 1. 1	12:40
002,	50.0 kg
02. 1. 1	12:50
003,	50.0 kg

TOTAL	150.0 kg

【 Print Format 2 】

Date, Time, Gross Weight, Tare Weight, Net Weight

02. 1. 1	12:30
Gross :	1000.0 kg
Tare :	0.0 kg
Net :	1000.0 kg
02. 1. 1	12:40
Gross :	2000.0 kg
Tare :	500.0 kg
Net :	1500.0 kg

Net TOTAL	2500.0 kg

Ref 1. After printing the total weight or when turning off the power and then it on, the serial No. is initialized to 001.

F44

Function	Input User's information to printing message	
Use Key ◀, ▶, ▲, ▼ : Data designation * : Increase coordinate	VFD Display	DESCRIPTION
	P12 - 065	Designate 'A'(ASCII code 65) in 12 th data.
	P00 - 032	Designate ASCII code 32 to 0 th data to print the added contents.
	P18 - 255	Designate ASCII code 255 to indicate the end of data after the last data

Ref 1. It is the function that adds contents in the print format.

(Ex: Company name, phone number)

Ref 2. The range of the coordinate is from 0 to 71.

The 0th code is used to choose between printing head message and no printing.

(032: Print, Others: Do not print)

What is actually printed is the content up until the coordinate indicated by the 1st through 255th data point.

Ref 3. If you want to add the company name "CAS" to the print format, do as follows.

P00-032(ASCII Code 32 : Data start position),

P01-067(ASCII Code 67 : Character C)

P02-065(ASCII Code 65 : Character A)

P03-083(ASCII Code 83 : Character S)

P04-255(ASCII Code 255: Data end position)

F45

Function	Set Print Operating Codition	
Set Value (0, 1)	VFD Display	DESCRIPTION
	F45 0	Print data in a state of stable & unstable
	F45 1	Print data in stable condition

Ref 4. ASCII Table

CHA	CODE	CHA	CODE	CHA	CODE	CHA	CODE	CHA	CODE	CHA	CODE
Space	32	0	48	@	64	P	80	`	96	p	112
!	33	1	49	A	65	Q	81	a	97	q	113
“	34	2	50	B	66	R	82	b	98	r	114
#	35	3	51	C	67	S	83	c	99	s	115
\$	36	4	52	D	68	T	84	d	100	t	116
%	37	5	53	E	69	U	85	e	101	u	117
&	38	6	54	F	70	V	86	f	102	v	118
‘	39	7	55	G	71	W	87	g	103	w	119
(40	8	56	H	72	X	88	h	104	x	120
)	41	9	57	I	73	Y	89	i	105	y	121
*	42	:	58	J	74	Z	90	j	106	z	122
+	43	;	59	K	75	[91	k	107	{	123
,	44	<	60	L	76	\	92	l	108		124
-	45	=	61	M	77]	93	m	109	}	125
.	46	>	62	N	78	^	94	n	110	~	126
/	47	?	63	O	79	_	95	o	111	End	255

5-3-4. Batching Operation Function

F50

Function	Measurement Mode		
Set Value (0~4)	VFD Display	DESCRIPTION	
	F50 0	Do not Use	
	F50 1	Customer Programmed Control Mode	Normal batching
	F50 2		Loss-in-weight batching
	F50 3	Built-in automatic program Mode	Normal batching
	F50 4		Loss-in-weight batching

※ Please refer to each operation on Page 70.

F53

Function	Timer - Start Delay Time	
Set Value (00~99)	VFD Display	DESCRIPTION
	F53 00	No delay time
	F53 10	1.0 sec
	F53 99	9.9 sec

Ref 1. . It is used only in the built-in automatic program Mode.

F54

Function	Timer - Finish Signal Start Delay Time	
Set Value (00~99)	VFD Display	DESCRIPTION
	F54 00	No delay time
	F54 10	1.0 sec
	F54 99	9.9 sec

Ref 1. It is used to set the delay time of the finish signal after the batching operation..

F55

Function	Timer - Finish Signal Operating Delay Time	
Set Value (00~99)	VFD Display	DESCRIPTION
	F55 00	Do not use
	F55 01	0.1 sec
	F55 99	9.9 sec

Ref 1. It is used to determine the output time of the finish signal after the batching operation.

Ref 2. If F55 and F56 are set at the same time, Err-Set is displayed and neither are stored.

Set this function to 00(Do not use) in case of using the function(F56) that sets the OFF range of the finish signal.

F56

Function	Finish Signal OFF Range	
Set Value (00~99)	VFD Display	DESCRIPTION
	F56 00	Do not use
	F56 01	Finish signal is off when the weight below one division
	F56 99	Finish signal is off when the weight below ninety nine division

Ref 1. If F55 and F56 are set at the same time, Err-Set is shown and neither are stored.

Set this function to 00(Do not use) in case of using the function(F55) that sets the delay time of the finish signal.

5-3-5. Option Function

F66

Function	Select Option Type	
Set Value (0 ~ 5)	VFD Display	DESCRIPTION
	F66 0	Do not use
	F66 1	BCD Out (Option-3)
	F66 2	Analog Out (Option-4, 5)
	F66 3	Current Loop (Option-1)
F66 4	BCD In (Option-6)	

F68

Function	Output Current of Voltage at Display Zero	
Set Value (0 ~ 24000)	VFD Display	DESCRIPTION
	L 00000	0 mA, 0V
	L 04000	4.000 mA, 2V
	L 04015	4.015 mA, 2.007V

F69

Function	Output Current of Voltage at Full Scale	
Set Value (0 ~ 24000)	VFD Display	DESCRIPTION
	H 10000	10 mA, 4.16V
	H 20000	20.000 mA, 8.33V
	H 24000	24.000 mA, 10V

F72

Function	Select Output Logic - BCD Out	
Set Value (0, 1)	VFD Display	DESCRIPTION
	F72 0	Positive Logic
	F72 1	Negative Logic

F73

Function	Set Point Input	
Set Value (0, 1)	VFD Display	DESCRIPTION
	F73 0	Disable external Set point input
	F73 1	Enable external Set point input

5-3-6. Input Set Point

F80

Function	Set Point 1 - Zero Band
o Set the zero band value which will be used in the batching operation with ◀,▶,▲,▼ key.	

F81

Function	Set Point 2 - Optional Preliminary Weight
o Set the optional preliminary weight which will be used in the batching operation with ◀,▶,▲,▼ key.	

F82

Function	Set Point 3 - Preliminary Weight
o Set the preliminary weight which will be used in the batching operation with ◀,▶,▲,▼ key.	

F83

Function	Set Point 4 - Final Weight
o Set the final weight which will be used in the batching operation with ◀,▶,▲,▼ key.	

F84

Function	Set Point 5 - Free Fall Weight
o Set the free fall weight which will be used in the batching operation with ◀,▶,▲,▼ key.	

F85

Function	Set Point 6 - High Limit Weight
o Set the high limit weight which will be used in the batching operation with ◀,▶,▲,▼ key.	

F86

Function	Set Point 7 - Low Limit Weight
o Set the low limit weight which will be used in batching operation with ◀,▶,▲,▼ key.	

5-3-7. Initialize Set Mode Value

F99

Function	Initialize Set Mode Value	
Set Value (0, 1)	VFD Display	DESCRIPTION
	INIT 0	Keep the current Set Mode Value
	INIT 1	Initialize the Set Mode Value

If you press the ENTER key when "INT 0" is displayed, the program will return to the set menu after "CANCEL"(canceling initialization) is displayed.

If you press the ENTER key when "INT 0" is displayed, program will return to the set menu after the value of the Set Mode is initialized and "INITIAL"(executing initialization) is displayed.

6. Test Mode

6-1. How to enter Test Mode

If you open the front cover of indicator and turn on the DIP S/W1, the Test Mode is started. At this time, TEST message is displayed on VFD and TEST 1 runs automatically.

If you turn on all of the DIP switches(1,1) after the Calibration, you can return to the Weighing Mode then.

1. *TEST 1* : select the Test menu which you would like to do.
2. Select the Test menu with arrow keys and then press the ENTER key
3. *TEST 1* : It means “Test 1”(key Test) is selected. Proceed the key Test.

6-2. Available Keys in Test Mode

▲, ▼ Key : Change the Test number value

▲ Key : increase a value

▼ Key : decrease a value

▶, ◀ Key : Change the digit of the set value

“*” Key : Cancel key

ENTER Key : The Test is executed or the program is moved into the next menu

6-3. Test Menu

Test 1 : Key Test

Test 2 : Display Test

Test 3 : A/D(Loadcell) Test

Test 4 : Serial(RS-232) Test (COM1, COM2)

Test 5 : Print Test

Test 6 : External Input / Output Test

Test 7 : BCD Out Test (Option – 3)

Test 8 : Analog Out Test (Option – 4,5)

Test 9 : BCD In Test (Input Set Point)

Test 10 : RTC(Real Time Clock) Test

Test 1

Function : Key Test		
Use Key	DISPLAY	DESCRIPTION
ENTER : Select menu Shift Mode	TEST 1	It means the Test Mode 1
Other key : Perform Test	1 1	Press any key to Test then the display show its number and code.

Ref1. Execute the Test 6 for the external input/output Test.

Ref2. Key list

KEY	ZERO	TARE	KEY TARE	GROSS/NET	*	ENTER
CODE	60	61	62	63	18	15

Test 2

Function : Display Test		
Use Key	DISPLAY	DESCRIPTION
*, ENTER : Select menu Shift Mode	TEST 2 8888888	It means the Test Mode 2 All on display segment

Test 3

Function : A/D(Loadcell) Test		
Use Key	DISPLAY	DESCRIPTION
▲ : display the value of A/D conversion	TEST 3	It means the Test Mode 3
▼ : display the value of mV/V	5324	It means the current A/D value
*, ENTER : Select menu Shift Mode	0.2500	0.2500mV/V. It means current load cell value

Ref 1. Check whether the output value of the load cell is changing while loading and removing the weight.
If the number is fixed or zero is displayed, please check the connection of the load cell.

Ref 2. The error of the output value of the load cell is within 10%.

Test 4

Function : Serial Test(COM1, COM2)		
Use Key	DISPLAY	DESCRIPTION
▲ : Transmit to PC after value increase	TEST 4	It means the Test Mode 4
▼ : Transmit to PC after value decrease	00---00	Wait for transmission and reception
	00---05	Transmit : 5, Receive : none
*, ENTER : Select menu Shift Mode	13---05	Transmit : 5, Receive :13

Ref 1. Execute this Test after the connection between serial port of PC and the COM port of the indicator, while working the hyper terminal of PC.

Ref 2. Send no.1 in the computer keyboard and check whether the indicator receives no.1.

Send no.1 in the indicator keyboard and check whether the computer receives no.1.

Ref 3. Execute this Test after specifying baud rate in the set Mode(F28, F32).

Refer to page 39.

Ref 4. Transmit and receive Test is available in COM1 and only transmit Test is available in COM2.

Test 5

Function : Print Test(COM2)		
Use Key	DISPLAY	DESCRIPTION
* , ENTER : Select menu Shift	TEST 5	It means the Test Mode 5
Mode Other key : Perform Test	Good	No error in printer

Ref 1. Specify the printer to use in the Set Mode(F40) in advance.

Ref 2. The “Good” message is displayed if the connection and specification of the printer is done correctly.

Ref 3. The Test output format of the printer is as follows.

CAS Corporation Come And Succeed TEL 1577-5578 Test OK

Test 6

Function : External Input/Output Test		
Use Key	DISPLAY	DESCRIPTION
▲, ▼ : Move external output. External input : Display external key * , ENTER : Select menu Shift	TEST 6	It means the Test Mode 6
Mode	In1oUt3	In1 : Press no.1 and then no.1 is inputted. oUt3 : It indicates the external output condition. Namely, no.3 is on.

Test 7

Function : BCD Out Test(Option-3)		
Use Key	DISPLAY	DESCRIPTION
▲ : Turn on key ▼ : Turn off key *, ENTER : Select menu Shift Mode	TEST 7	It means the Test Mode 7.
	ALL on	ALL on : all BCD output on
	ALL oFF	ALL oFF : all BCD output off.

Ref 1. You can not separately Test each line of BCD OUT in Test 7 but can check the whole operation.

Ref 2. Check the setting of the option card in Test.

Test 8

Function : Analog Out Test(Option-4, 5)		
Use Key	DISPLAY	DESCRIPTION
◀ : Zero value setting ▶ : High value setting ▼ : Zero output value Test (4mA / 0V) ▲ : High Output value Test (20mA / 10V) *, ENTER : Select menu Shift Mode	TEST 8	It means the Test Mode 8
	L 04000	Set the value of zero output to 4.00mA
	H 20000	Set the value of high output to 20.00mA
	HiGH	HiGH : Output the value of maximum weight. (Adjust to 20mA / 10V)
	Zero	Zero : Output the zero value (Adjust to 4mA / 0V)

Ref 1. You can Test by designating the operation range.

Ref 2. Check the setting of the option card in the Test.

Test 9

Function : BCD In(Input Set Point)Test (Option)		
Use Key	DISPLAY	DESCRIPTION
▲ : Digit Increase ▼ : Digit Decrease [*] : Cancel Enter : Enter the Test	TEST 9 XX L=YY	It means the Test Mode 9 XX : Display a digit (0~15) YY : Display value of a digit(0-9)

Pin	Signal	Digit	Pin	Signal	Digit
1	1		14	Prelim. 10 ¹ common	9
2	2		15	Prelim. 10 ² common	10
3	4		16	Prelim. 10 ³ common	11
4	8		17	High limit 10 ⁰ common	12
5	Final weight 10 ⁰ common	0	18	High limit 10 ¹ common	13
6	Final weight 10 ¹ common	1	19	Low limit 10 ⁰ common	14
7	Final weight 10 ² common	2	20	Low limit 10 ¹ common	15
8	Final weight 10 ³ common	3	21		
9	Final weight 10 ⁴ common	4	22		
10	Free fall 10 ⁰ common	5	23		
11	Free fall 10 ¹ common	6	24	GND Shield	
12	Free fall 10 ² common	7	25	GND Shield	
13	Prelim. 10 ⁰ common	8			

Test 10

Function : RTC(Real Time Clock) Test		
Use Key	DISPLAY	DESCRIPTION
[*] : Cancel Enter : Enter the Test	TEST 10 SEC XX	It means the Test Mode 10 XX : It means second

7. Weighing Mode

7-1. How to enter Weighing Mode

If you open the front cover of indicator and turn on all of the DIP S/W, the Weighing Mode is started.

□ DIP SWITCH : MODE TABLE

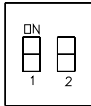

DIP S/W		Indicator Mode
0	0	Test Mode (Test)
0	1	Calibration Mode (CAL)
1	0	Set Mode (SET)
1	1	Weighing Mode (WEIGHING)

7-2. Available Keys in Weighing Mode

ZERO

- Execute the zero Calibration. it makes the present value 0kg.
(It works within the range of the digital zero regulation value.)

TARE

- Use the tare in weighing.
- Memorize the tare weight and the display NET value which the weight is subtracted from the total weight.

PRESET
TARE

- Use it to input the tare weight manually.
- “t 0000” is displayed if pressing the PRESET TARE key.
The tare weight is inputted if pressing the ENTER key after inputting the value of it with arrow keys.

GROSS
NET

- Display G/N weight by turns on the VFD screen
- Front key used, not used setting.
(The program is converted to input Mode by pressing the key for more than 3 sec.)

*

- “*” key is used in various ways.
- Set Point value for the batching operation.
(The program is converted to input Mode by pressing the key for more than 2sec.)

- It is used as the set function in the set Mode 17.

0. Do not use.

1. Print Key
2. Hold Key

ENTER

- The ENTER key is used in various ways.
- Set Point code for the batching operation.
(The program is converted to input Mode by pressing key for more than 2sec.)

- It is used as the set function in the set Mode 18.

0. Do not use

1. Total Print key
2. Start key in the batching system
3. Stop key in the batching system

7-3. External Control (Input / Output) Interface

External Control Input

Pin No	Signal	설 명
24, 25	GND (Input Common)	o External Input Common
16	ZERO	o It brings the Gross weight to zero
17	TARE	o It is used to weigh with the tare.
18	START	o It is used as the Start key in the batching operation
19	STOP	o It is used as the Stop key in the batching operation.
20	‘ * ‘	o It is used as the set function in SET Mode F17. Refer to page 36.
21	ENTER	o It is used as the set function in SET Mode F18. Refer to page 36

External Control Output

The output is done according to the following condition in batching operation.

Pin No	MODE	Output	Terms
3	ALL	Zero Band	Gross Weight \leq S.P1(Zero band)
4	NORMAL	Optional preliminary weight output	Net weight \geq S.P4 (Final weight) – Optional preliminary weight
	Loss-in	Optional preliminary weight output	Gross weight $>$ S.P2(Optional preliminary weight)
5	ALL	Preliminary weight output	Net weight \geq S.P4(Final weight) -S.P3(Preliminary weight)
6	ALL	Final weight output	Net weight \geq S.P4(Final weight) – S.P5(Free fall weight)
7	ALL	High Limit	Net weight $>$ S.P4(Final weight) + S.P6(High limit weight)
8	ALL	Low Limit	Net weight $<$ S.P4(Final weight) – S.P7(Low limit weight)
9	ALL	Finish	It is outputted according to Finish output time setting
10	ALL	Stable	It is outputted when the weight is stable.
11	ALL	External Output Common	

■ External Control I/O Circuit

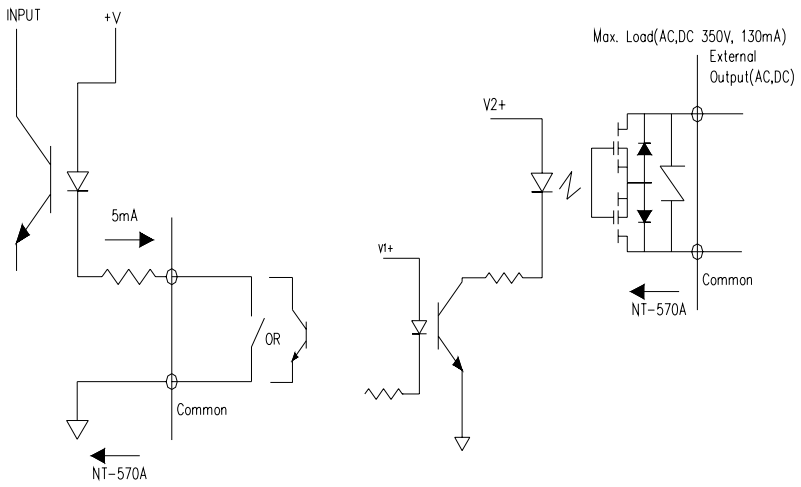

7-4. Item Code(Range : 00 ~99)

The Item Code is used to classify several batching operations.

The Item Code consists of one hundred codes and each code is allotted 7 Set Point values.

Set Point No	I.Code-0	I. Code-1	I. Code-X	I. Code-98	I. Code-99
Set Point-1	S.P(0)-1	S.P(1)-1	S.P(X)-1	S.P(48)-1	S.P(49)-1
Set Point-2	S.P(0)-2	S.P(1)-2	S.P(X)-2	S.P(48)-2	S.P(49)-2
Set Point-3	S.P(0)-3	S.P(1)-3	S.P(X)-3	S.P(48)-3	S.P(49)-3
*	*	*	*	*	*
*	*	*	*	*	*
*	*	*	*	*	*
Set Point-6	S.P(0)-6	S.P(1)-6	S.P(X)-6	S.P(48)-6	S.P(49)-6
Set Point-7	S.P(0)-7	S.P(1)-7	S.P(X)-7	S.P(48)-7	S.P(49)-7

Ref. S.P = Set Point, I.CODE = Item Code

The Item Code can be inputted in the two following ways.

- The code value can be set in the Weighing Mode by pressing the ENTER key for 2 sec.

DISPLAY	DESCRIPTION
Code=00	Set one of total 100 codes to 00 in batching operation.
Code=99	Set one of total 100 codes to 99 in batching operation.

The changed code is activated by pressing the ENTER key.

The code change is canceled and the code before changed is kept by pressing the “*” key.

- You can do setting through the RS-232C, RS-485 communication.

(The Command Mode is that the set value of F31 in the Set Mode is set to 4.)

Refer to the Set Mode (page 39,40)

7-5. Set Point Input

The Set Point input is used to set the value of each point for the three step control in the batching operation.

The Set Point is allotted according to the designated Item code in '7-4' and can be inputted from Set Point 1 to Set Point 7.

The Set Point value can be inputted in the four following ways

- The way to input with the keys in the Weighing Mode.
- The way to input with the external BCD Code in the Weighing Mode.(Option)
- The way to input with the keys in the Set Mode.(Refer to page 50)
- The way to input through the RS-232C, RS-485 communication. (Refer to page 41)

- if pressing the “ * ” key for 2 sec, the Weighing Mode is changed to the Set Point input Mode and then the set value should be inputted directly.

Ref 1. Set the value of F73 in the set Mode to 1.

Ref 2. Move the digit with the “▶, ◀” key and then move to the next step with the “▲, ▼” key after inputting the setting value.

Press the “ * ” key to leave the Set Mode without saving.

Set Point No	DISPLAY	DESCRIPTION
Set Point-1	ZErO bA	o Input is started by pressing the "ENTER " key.
	1-00000	o It means the zero band.
Set Point-2	oP-Pre	o It means the Optional Preliminary.
	2-00000	o Input the Optional Preliminary.
Set Point-3	PrELiM	o It means the Preliminary Weight.
	3-00000	o Input the Preliminary Weight.
Set Point-4	FinAL	o It means the Final Weight.
	4-00000	o Input the Final Weight.
Set Point-5	FALL	o It means the Free Fall Weight.
	5- 0000	o Input the Free Fall Weight.
Set Point-6	H-LiMit	o It means the High Limit Weight.
	6- 0000	o Input the High Limit Weight.
Set Point-7	L-LiMit	o It means the Low Limit Weight.
	7- 0000	o Input the Low Limit Weight.

7-6. Regulation of Input Set Point

Set Point No	Regulation
Zero Band Set Point-1	Maximum Value > Set Point-1
oP-Pre Set Point-2	Maximum Value > Set Point-2
PrELim Set Point-3	Set Point-2 > Set Point-3
Final Set Point-4	Maximum Value > Set Point-4
Fall Set Point-5	Set Point-3 > Set Point-5
High Limit Set Point-6	Maximum Value > Set Point-6
Low Limit Set Point-7	Maximum Value > Set Point-7

Ref 1. When the Set Point value is wrong for the regulation, then “Err” is displayed and the Set Point value is initialized to ‘0’.

Ref 2. The Regulation has to be observed for the sequential 3 step control and the 1st~3rd step outputs are computed as follows.

1st Step Output = Final(Set Point 4) – Optional preliminary(Set Point 2)

2nd Step Output = Final(Set Point 4) – Preliminary(Set Point 3)

3rd Step Output = Final(Set Point 4) – Free fall(Set Point 5)

7-7. Batching Operation

NT-580 supports the four batching operation methods.

The specification of the batching operation method is selected in the Set Mode F50. (Refer to page 46)

A. User Program Control Mode

- Normal Batching
- Loss-in-Weight Batching

B. Automatic Program Control Mode

- Normal Batching
- Loss-in-Weight Batching

Normal Batching Diagram

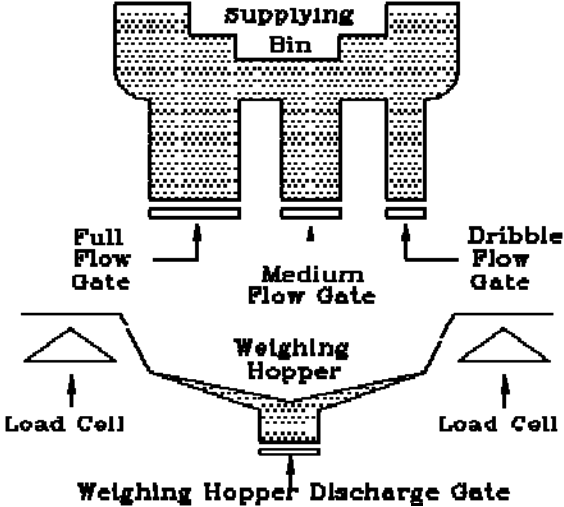

Loss-in-Weight Batching Diagram

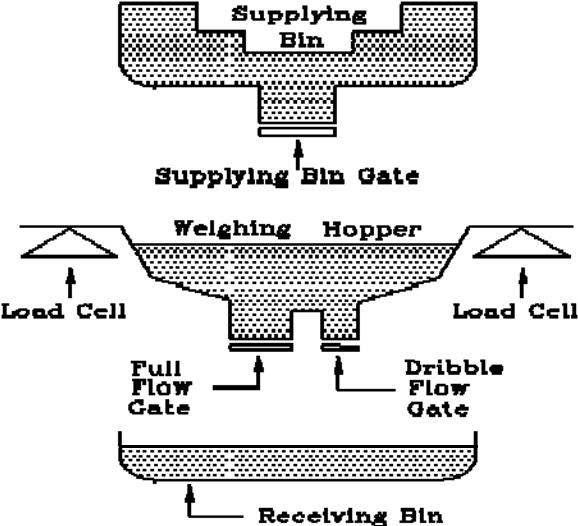

User Program Control Mode

Normal Batching

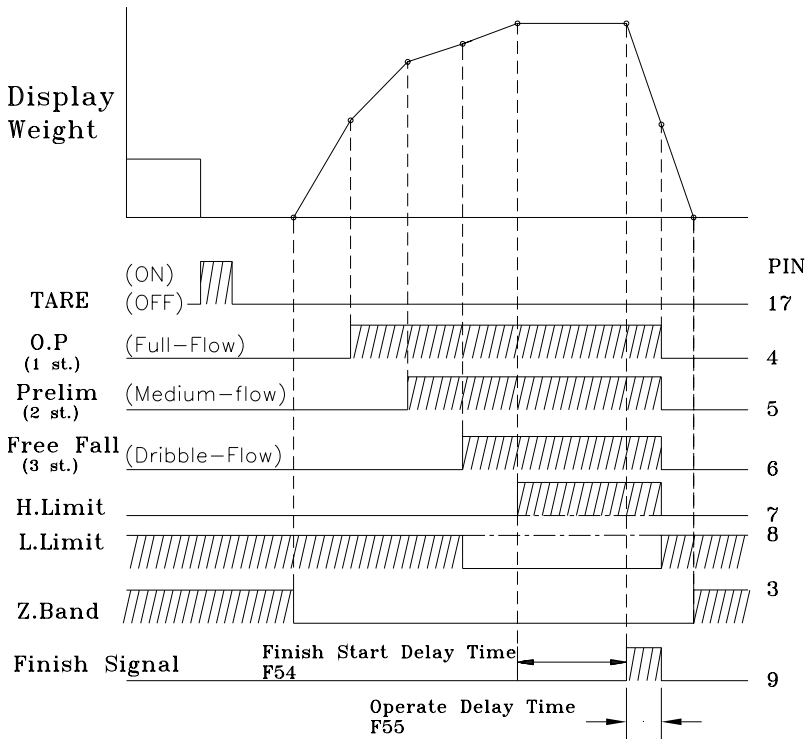
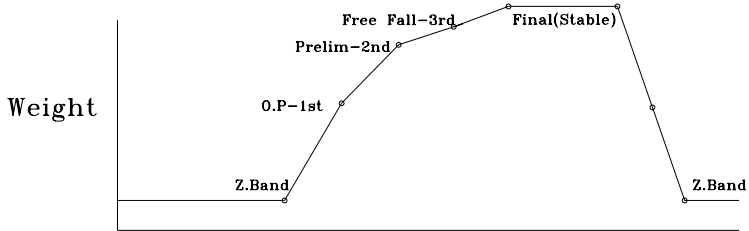

■ The external control could be done in favor of user as the above timing chart in the user program control Mode.

■ The external input and output signal is like follows.

1. Press the TARE key so that the display value(NET weight) could be 0kg.

2. Zero BAND OUTPUT:

It is ON when GROSS weight is smaller than the ZERO BAND value(S.P1).

3. FIRST OUTPUT(Optional preliminary):

It is ON when the NET weight is more than the set weight(Final(S.P4) – Optional preliminary (S.P2)).

4. SECOND OUTPUT(Preliminary):

It is ON when the NET weight is more than the set weight(Final(S.P4) - Preliminary(S.P2)).

5. Third OUTPUT(Final):

It is ON when the NET weight is more than the set weight(Final(S.P4) – Free fall(S.P5)).

6. HIGH LIMIT OUTPUT:

It is ON when the NET weight is more than the set weight(Final(S.P4) + High limit(S.P6)) after the third output is ON.

7. LOW LIMIT OUTPUT:

It is ON when the NET weight is smaller than the set weight(Final(S.P4) – Low limit(S.P7)) after the third output is ON.

8. FINISH OUTPUT:

When the weight is stable, it is ON after the delay time that is specified in F54

It is OFF after the delay time that is specified in F55 or within the Finish Signal OFF Range that is specified in F56.

Ref. The Discharge Gate control signal could not be supplied in the NT-580A.

-Use the FINISH OUTPUT SIGNAL properly.

User Program Control Mode
Loss-in-Weight Batching

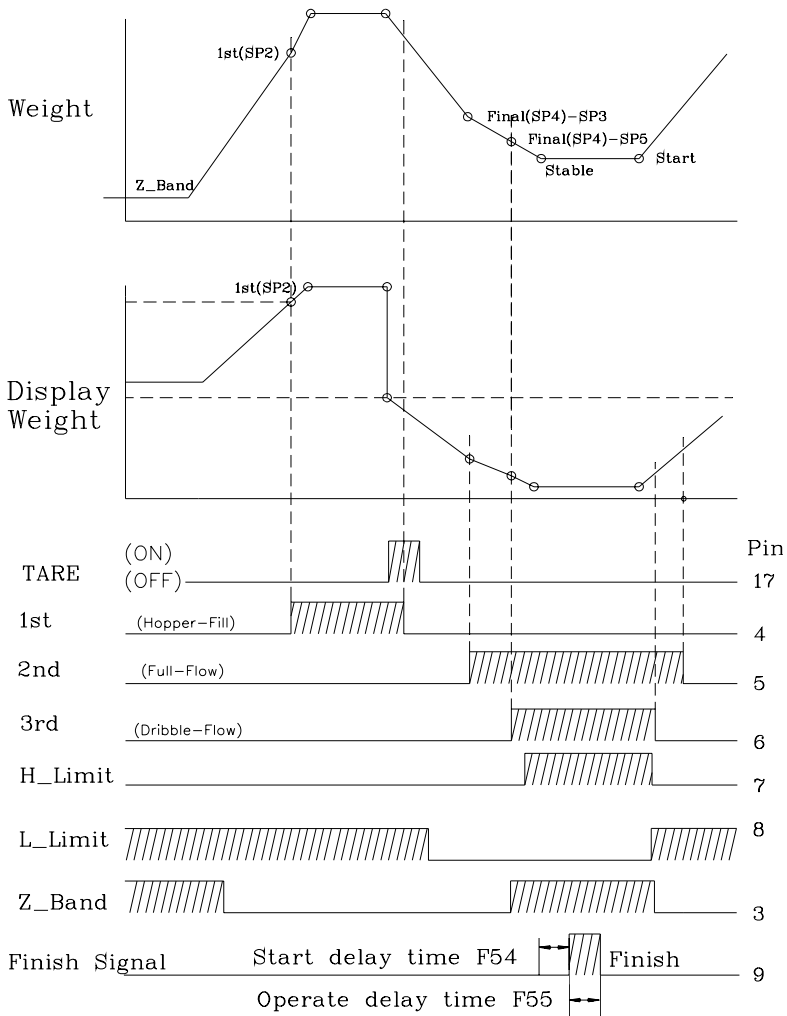

■ The external control could be done in favor of user as the above timing chart in the user program control Mode.

■ The external input and output signal is like follows.

1. Zero BAND OUTPUT:

It is ON when the GROSS weight is smaller than the zero band value(S.P1).

2. FIRST OUTPUT(Optional preliminary):

It is ON when the GROSS weight is bigger than the optional preliminary weight(S.P2).

It is OFF when the GROSS weight is smaller than the optional preliminary weight(S.P2).

-Fill in the hopper by using the first output signal in the next batching operation.

3. Press TARE key so that the display value(NET weight) could be 0kg.

4. SECOND OUTPUT(Preliminary):

It is ON when the NET weight is more than the set weight(Final(S.P4) –Preliminary(S.P3)).

5. Third OUTPUT(Final):

It is ON when the NET weight is more than the set weight(Final(S.P4) –Free fall(S.P5)).

6. HIGH LIMIT OUTPUT:

It is ON when the NET weight is more than the set weight(Final(S.P4) + High limit(S.P6)) after the third output is ON.

7. LOW LIMIT OUTPUT:

It is ON when the NET weight is smaller than the set weight(Final(S.P4) –Low limit(S.P7)) after the third output is ON.

8. FINISH OUTPUT:

When the NET weight is more than the Final value regardless of stability, it is ON after the delay time that is specified in F54.

It is OFF after the delay time that is specified in F55 or within the Finish Signal OFF Range that is specified in F56.

Ref. The Discharge Gate control signal could not be supplied in the NT-580A.

-Use the FINISH OUTPUT SIGNAL properly.

Automatic Program Control Mode

Normal Batching

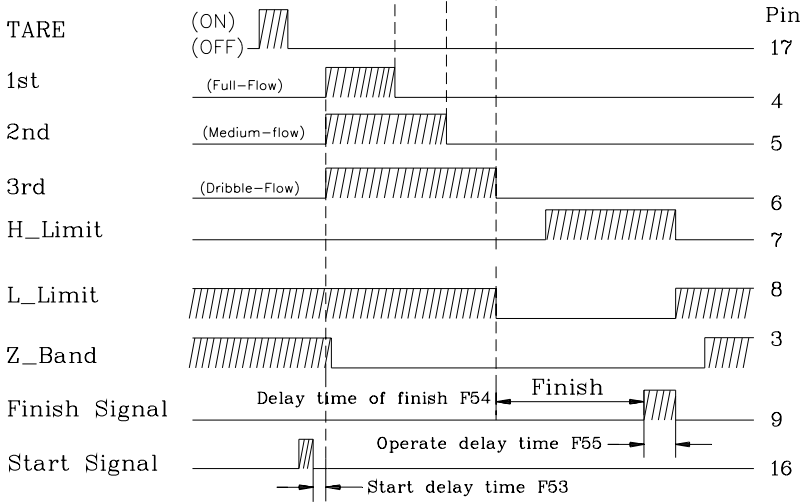
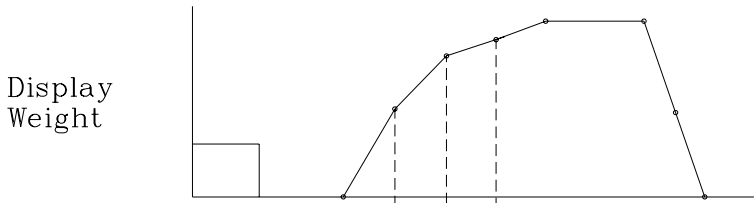
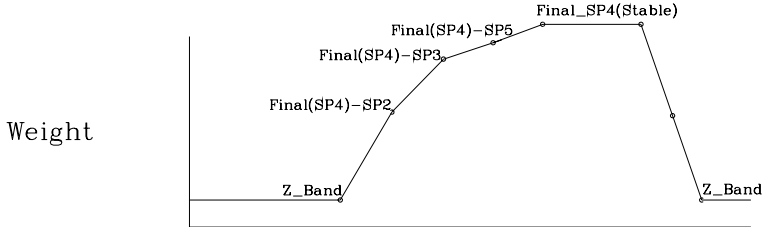

■ The output/input is controlled as it is programmed in the indicator as the above timing chart in the automatic program control Mode.

■ The external input and output signal is like follows.

1. Press the TARE key so that the display value(NET weight) could be 0kg.

2. Zero BAND OUTPUT:

It is ON when the GROSS weight is smaller than the zero band value(S.P1).

3. START INPUT:

FIRST, SECOND, THIRD output is ON when the START key is pressed after the delay time that is specified in F54.

4. FIRST OUTPUT:

It is OFF when the NET weight is more than the computed weight(Final(S.P4)–Optional preliminary(S.P2)).

5. SECOND OUTPUT(Preliminary):

It is OFF when the NET weight is more than the computed weight(Final(S.P4) - Preliminary(S.P3)).

6. THIRD OUTPUT(Final):

It is OFF when the NET weight is more than the computed weight(Final(S.P4)–Free fall(S.P5)).

7. HIGH LIMIT OUTPUT:

It is ON when the NET weight is more than the computed weight(Final(S.P4) + High limit(S.P6)) after the third output is OFF.

8. LOW LIMIT OUTPUT:

It is ON when the NET weight is smaller than the computed weight(Final(S.P4)–Low limit(S.P7)) after the third output is OFF.

9. FINISH OUTPUT:

When the weight is stable, it is ON after the delay time that is specified in F54

It is OFF after the delay time that is specified in F55 or within the Finish Signal OFF Range that is specified in F56.

Ref. The Discharge Gate control signal could not be supplied in the NT-580A.

-Use the FINISH OUTPUT SIGNAL properly.

Automatic Program Control Mode

Loss-in-Weight Batching

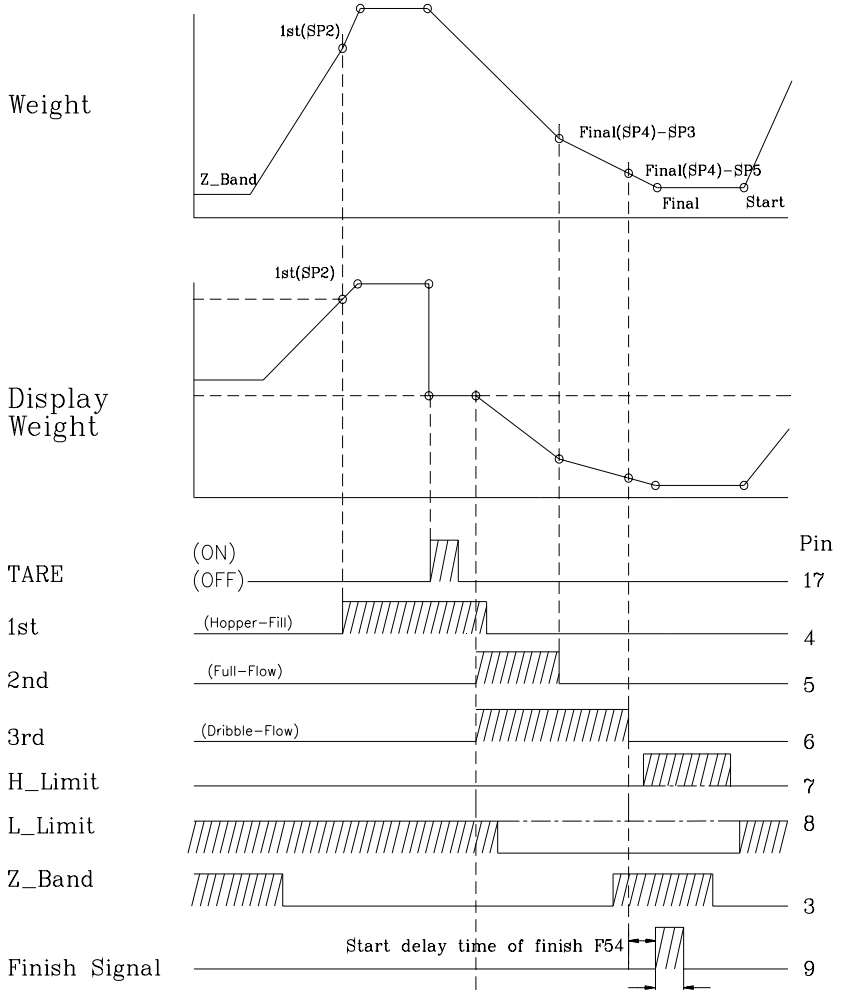

■ The output/input is controlled as it is programmed in the indicator as the above timing chart in the automatic program control Mode.

■ The external input and output signal is like follows.

1. ZERO BAND OUTPUT:

It is ON when the GROSS weight is smaller than the zero band value(S.P1).

2. It is ON when the GROSS weight is bigger than the optional preliminary weight(S.P2).

It is OFF when the GROSS weight is smaller than the optional preliminary weight(S.P2).

- When the first output is OFF in the next batching operation, it is not ON although the START input is OFF.

- Fill in the hopper by using the first output signal in the next batching operation.

3. Press the TARE key so that the display value(NET weight) could be 0kg.

4. START INPUT:

SECOND and THIRD output are ON when the START key is pressed after the delay time that is specified in F53.

5. SECOND OUTPUT(Preliminary):

It is OFF when the NET weight is more than the set weight(Final(S.P4) - Preliminary(S.P3)).

6. THIRD OUTPUT(Final):

It is OFF when the NET weight is more than the computed weight(Final(S.P4) –Free fall(S.P5)).

7. HIGH LIMIT OUTPUT:

It is ON when the NET weight is more than the set weight(Final(S.P4) + High limit(S.P6)) after the third output is OFF.

8. LOW LIMIT OUTPUT:

It is ON when the NET weight is smaller than the set weight(Final(S.P4) –Low limit(S.P7)) after the third output is OFF.

9.FINISH OUTPUT:

When the NET weight is more than the Final value regardless of stability, it is ON after the delay time that is specified in F54.

It is OFF after the delay time that is specified in F55 or within the Finish Signal OFF Range that is specified in F56.

Ref. The Discharge Gate control signal could not be supplied in the NT-580A.

-Use the FINISH OUTPUT SIGNAL properly.

8. Serial Communication (RS-232C)

8-1. RS232C Connection

① How to Connect PC

Connect the serial port on the rear panel of the indicator to the serial port of PC as follows.

COM1 - TXD: 2, RXD: 3, GND: 7

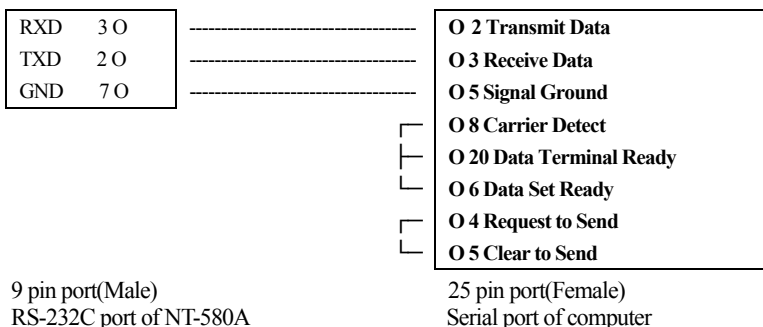

COM2 - TXD: 2, RXD: 3, GND: 7

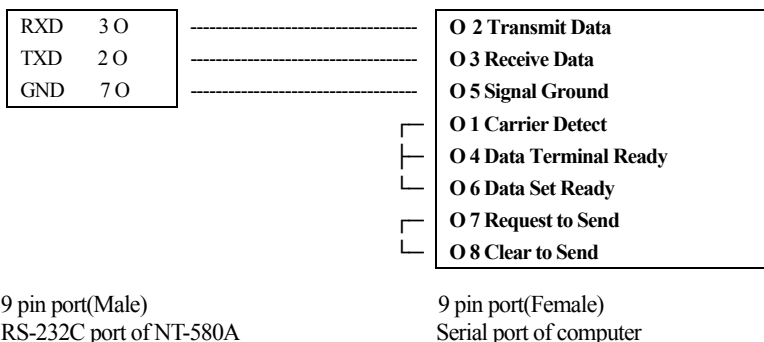

8-2. Serial Communication Device Connection

8-2-1. Sub Display Connection

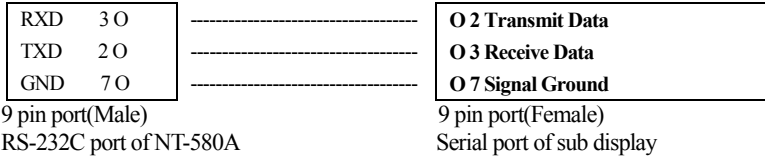

8-2-2. CAS Top Printer Connection

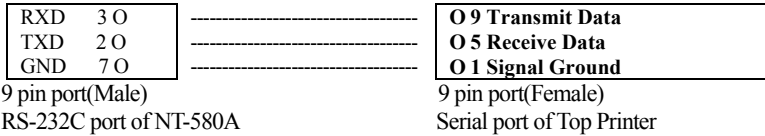

8-2-3. CP-7000 Series Printer Connection

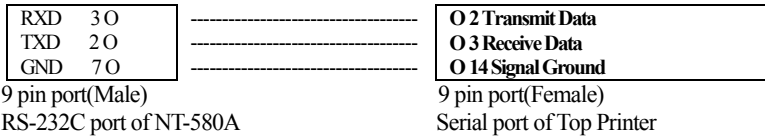

Ref. Refer to page 38(SET Mode) for the RS-232C communication and the setting method.

8-4. Simple Interface Program

```
* Language : Basic
10 OPEN "COM1:9600,N,8,1" As #1
20 IF LOC(1)=0 THEN 60
30 AS=INPUT$(1,1)
40 PRINT AS ; " ";
50 GOTO 20
60 BS=INKEY$ : IF BS="" THEN 20
70 PRINT BS ; " ";
80 PRINT #1,BS;
90 GOTO 20
```

```
* Language : C
#include <bios.h>
#include <conio.h>

#define COM1 0
#define DATA_READY 0x100
#define TRUE 1
#define FALSE 0

#define SETTINGS 0xE3

int main(void)
{
    int in, out, status, DONE = FALSE;

    bioscom(0, SETTINGS, COM1);
    printf("... BIOSCOM [ESC] to exit ...\n");
    while (!DONE)
    {
        status = bioscom(3, 0, COM1);
        if (status & DATA_READY)
            if ((out = bioscom(2, 0, COM1) & 0x7F) != 0)
                putchar(out);
            if (kbhit())
            {
                if ((in = getch()) == '\x1B')
                    DONE = TRUE;
                bioscom(1, in, COM1);
            }
    }
    return 0;
}
```

9. Option

9-1. Current Loop Serial Out

- Transmit Mode : Same as RS-232C

F27	Baud Rate	600, 1200, 2400bps
F30	Output Mode	Stable, Unstable, Data is required

- Signal Format : Same as RS-232C

1	20 mA
0	0 mA

- Data Format : Same as RS-232C

- Current Loop Pin Connection (25pin D-type male port)

Pin No	Signal
9	Current Loop Output
7	Ground
11	Current Loop Output
18	Ground
25	Current Loop Input

9-2. RS-485 Serial Interface

- Transmit Mode : Same as RS-232C

F27	Baud Rate	600,1200, 2400, 4800, 9600, 19200bps
F30	Output Mode	Stable, Unstable, Data is required

- Signal Format : : Same as RS-232C

1	20 mA
0	0 mA

- Data Format : : Same as RS-232C

- RS-485 Pin Connection

IN(+)	1 O
OUT(-)	4 O
IN(-)	5 O
OUT(+)	6 O
GND	7 O

-----	O 2 Transmit Data(+)
-----	O 15 Receive Data(-)
-----	O 14 Transmit Data(+)
-----	O 3 Receive Data(-)
-----	O 1 Ground
└	O 7 Ground
---	O 4,5,6,8 Wire Connect
---	O 16,17,18,19 Wire conn.

9 pin port(Male)
RS-232C port of NT-580A

25 pin port(Female)
Serial port of computer

9-3. BCD Out Interface

The Parallel BCD out is the interface that indicates the weight in display as BCD code.

The Inner circuit of input/output circuit is electronically disconnected by photo coupler.

■ Transmit Mode

F72	Output Logic	- Positive Logic - Negative Logic
-----	--------------	-----------------------------------

■ Connection of Pin

Pin	Signal	Pin	Signal
1	Ground (GND)	26	High : Net, Low : Gross
2	1st Digit - 1×10^0	27	N.C.
3	1st Digit - 2×10^0	28	N.C.
4	1st Digit - 4×10^0	29	N.C.
5	1st Digit - 8×10^0	30	N.C.
6	2nd Digit - 1×10^1	31	N.C.
7	2nd Digit - 2×10^1	32	N.C.
8	2nd Digit - 4×10^1	33	N.C.
9	2nd Digit - 8×10^1	34	N.C.
10	3rd Digit - 1×10^2	35	N.C.
11	3rd Digit - 2×10^2	36	N.C.
12	3rd Digit - 4×10^2	37	External Vcc
13	3rd Digit - 8×10^2	38	N.C.
14	4th Digit - 1×10^3	39	External Vcc
15	4th Digit - 2×10^3	40	N.C.
16	4th Digit - 4×10^3	41	N.C.
17	4th Digit - 8×10^3	42	High : +, Low : -
18	5th Digit - 1×10^4	43	Decimal Point : 10^1
19	5th Digit - 2×10^4	44	Decimal Point : 10^2
20	5th Digit - 4×10^4	45	Decimal Point : 10^3
21	5th Digit - 8×10^4	46	Over Load
22	6th Digit - 1×10^5	47	N.C.
23	6th Digit - 2×10^5	48	N.C.
24	6th Digit - 4×10^5	49	Busy
25	6th Digit - 8×10^5	50	

■ 50 pin connector : CHAMP 57-40500(Amphentol) (Female)

■ TTL Open-Collector Output

■ Signal Logic

- (1) BCD Data Output : Positive , Negative)
- (2) Polarity Output : “+” = High
- (3) OVER Output : “OVER” = High
- (4) BUSY Output : “BUSY” = High

■ Standard Accessory : Mating Connector 57-30500(Amphentol - Male) 1EA

■ Weight Data

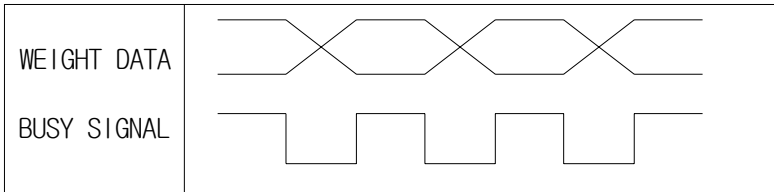

■ BCD Output Circuit

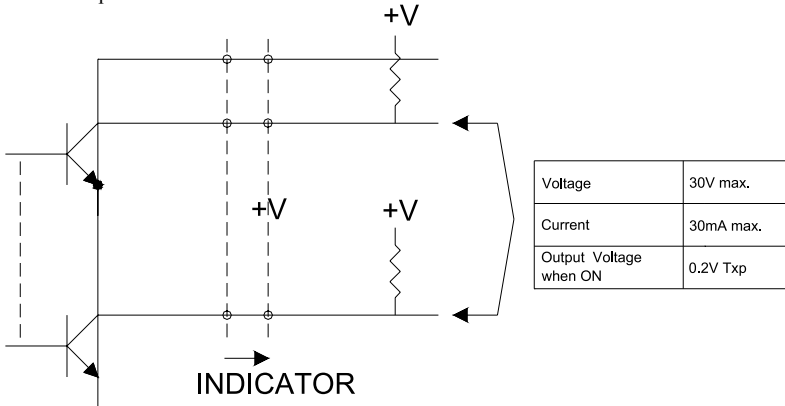

(1) BCD Output Circuit is Open collector type

(2) Input the proper power to the external power port of the connector 37 and 39 if the peripheral equipment has no Pull-up resistor.

9-4. Analog Out Interface(4~20mA)

■ Set F66=2

■ Specification

Output Current	4 - 20mA
Resolution	More than 1/1000
Temperature computation	0.01%/°C
Max Load Impedance	500Ω MAX.

■ The output current is 4mA when the display weight is “0”.

And the output current is 20mA when the display weight is the maximum capacity.

■ Minute adjustment of Output current

(1)The output current is 4mA in a factory shipment when the display weight is “0”

And the output current is 20mA in a factory shipment when the display weight is the maximum capacity.

(2)Adjust VR₁(zero), VR₂(span) of the option PCB in the indicator if the output current is not correct.

■ When the current is used as the voltage

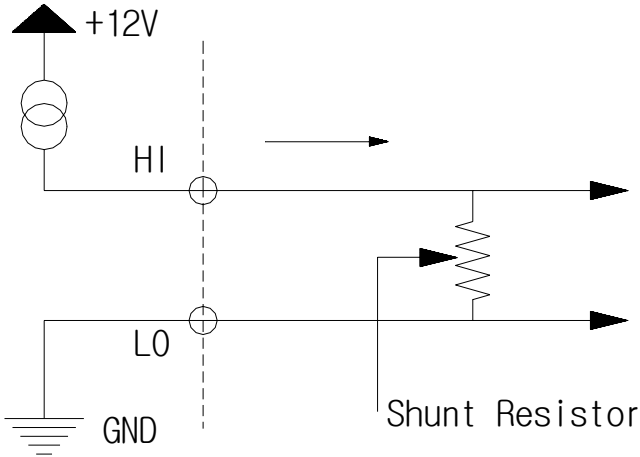

*When the resistor is 200Ω, the output voltage is 0.8V - 4V.

■ Analog Out PCB S/W Setting

(1) Model Select (SW3)

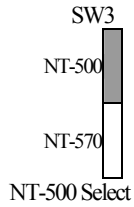

(2) Current Output Range Setting (SW1, SW2)

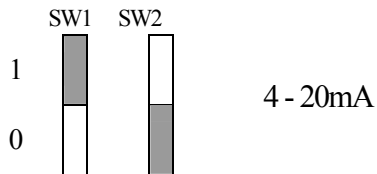
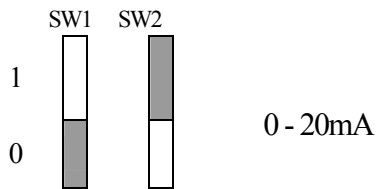
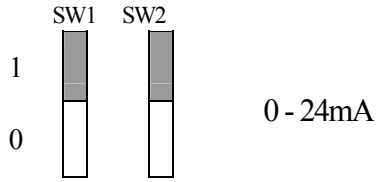

3) Output Minute Adjustment & Setting (SW4, SW5)



Fixing

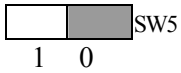

Flexibility

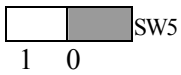

- The ZERO output of Analog Output can be set in the Test Mode 8 or the Set Mode F68.
- The HIGH output of Analog Output can be set in the Test Mode 8 or the Set Mode F69.

9-5. Analog Out Interface(0~10V)

■ Set F66=2

■ Specification

Output voltage	0-10V
Resolution	More than1/1000
Temperature Coefficient	0.01%/°C

■ The output voltage is 0V when the display weight is “0”.

And the output voltage is 10V when the display weight is the maximum capacity.

■ Minute adjustment of Output current

(1)The output voltage is 0V in a factory shipment when the display weight is “0”

And the output voltage is 10V in a factory shipment when the display weight is the maximum capacity.

(2)Adjust VR₁(zero), VR₂(span) of the option PCB in the indicator if the output current is not correct.

■ Analog Out PCB S/W Setting

(1) Model Selection (SW3)

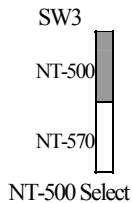

(2) Voltage output range setting(SW1, SW2)

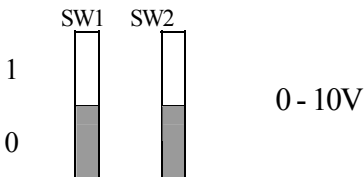

(3) Output Minute Adjustment & Setting (SW4, SW5)



Fixing

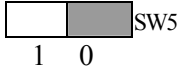

Flexibility

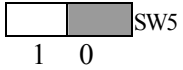

- The ZERO output of Analog Output can be set in the Test Mode 8 or the Set Mode F68.
- The HIGH output of Analog Output can be set in the Test Mode 8 or the Set Mode F69.

9-6. BCD In Interface

■ It is inputted through the external Set Point input port.
 Ref. Set F73 = 1(This function is option)

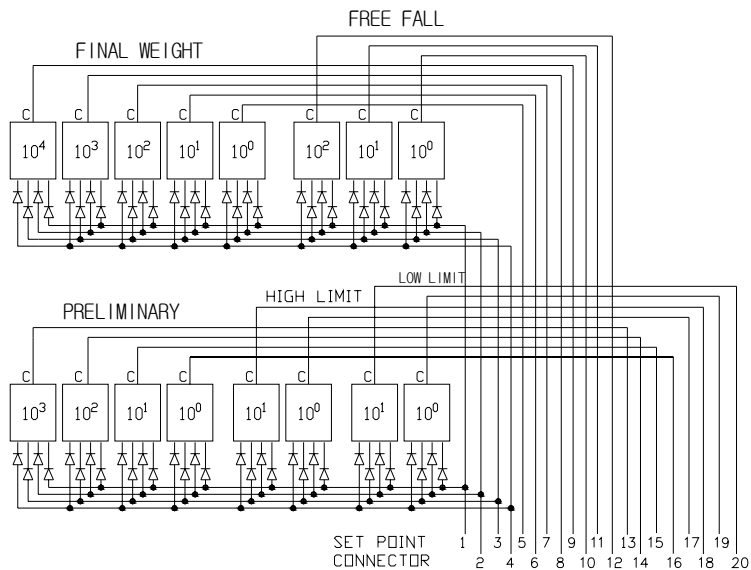

Pin No	Signal	Pin No	Signal	
1	BCD Code 2^0	13	Preliminary 10^0 Common	
2	BCD Code 2^1	14		10^1 Common
3	BCD Code 2^2	15		
4	BCD Code 2^3	16		10^3 Common
5	Final 10^0 Common	10^1 Common	17	High Limit 10^0 Common
6		10^1 Common	18	
7		10^2 Common	19	Low Limit 10^0 Common
8		10^3 Common	20	
9	10^4 Common	21 ~ 23	-	
10	Fall 10^0 Common		10^0 Common	-
11			10^1 Common	GND Shield
12		10^2 Common	GND Shield	

Regulation of Input Set Point

Set Point No	Regulation
Zero Band Set Point-1	Maximum Value > Set Point-1
oP-Pre Set Point-2	Maximum Value > Set Point-2
PrELim Set Point-3	Set Point-2 > Set Point-3
Final Set Point-4	Maximum Value > Set Point-4
Fall Set Point-5	Set Point-3 > Set Point-5
High Limit Set Point-6	Maximum Value > Set Point-6
Low Limit Set Point-7	Maximum Value > Set Point-7

Ref 1. When the Set Point value is wrong for the regulation, then “Err” is displayed and the Set Point value is initialized to ‘0’.

Ref 2. The Regulation has to be observed for the sequential 3 step control and the 1st ~3rd step outputs are computed as follows.

1st Step Output = Final (Set Point 4) – Optional preliminary (Set Point 2)

2nd Step Output = Final (Set Point 4) – Preliminary (Set Point 3)

3rd Step Output = Final (Set Point 4) – Free fall (Set Point 5)

10. Error Message

10-1. Error message in the Calibration Mode

Err No	Origin	Solution
Err 20	The resolution is set to be exceeded the limit 1/10,000	Low the resolution. The resolution = one division/the allowed maximum weight. Modify the allowed maximum weight in CAL1 or modify the division in CAL3 so that the resolution should be below 1/10,000.
Err 21	The resolution is set to be exceeded the limit 1/10,000	Low the resolution. The resolution = one division/the allowed maximum weight. Modify the allowed maximum weight in CAL1 or modify the division in CAL3 so that the resolution should be below 1/10,000.
Err 22	The weight for the Span Calibration is set to be less than 10% of the maximum capacity of the scale.	Set the weight for the Span Calibration in CAL4 is set to be more than 10% of the maximum capacity of the scale(set in CAL1).
Err 23	The weight for the Span Calibration is set to be exceeded 100% of the maximum capacity of the scale.	Set the weight for the Span Calibration in CAL4 to be within the maximum capacity of the scale(set in CAL1).
Err 24	The Span value is too low.	The setting of current resolution is not possible due to the error in the load cell or the low output of it. Proceed the Calibration again with the less resolution.
Err 25	The Span value is too high.	There is a error in the load cell and the output in the load cell is too high. Proceed the Calibration in CAL again.
Err 26	The Zero value is too high.	Check whether the platform is empty. If the SW on the AD PCB is ON, the zero value is decreased. Proceed the Calibration again after checking in the Test Mode 3.
Err 27	The Zero value is too low.	Check whether the platform is pressed by certain force. If the SW on the AD PCB is OFF, the zero value is increased. Proceed the Calibration again after checking in the Test Mode 3.
Err 28	The Weight is unstable.	Check whether the load cell is properly connected.

10-2. Error message in the Weighing Mode

Err No	Origin	Solution
Err 01	The weight is too unstable to initialize the scale.	Lay the scale on a flat place and turn on the power.
Err 02	The Load cell connection is failed or an error occurs in A/D conversion part.	Check the load cell connector to see if the polarity of the signal is reversed.
Err 05	Any key is pressed for a long time or the key part has problem.	Contact the service center.
Err 08	The ZERO key or TARE key is adjusted not to be operated under the unstable condition.	Reset the operational condition of the ZERO and TARE key in the Set Mode F14.
Err 09	The Current weight deviates from the zero range.	Set the operational range of the ZERO key within 2% or 10% of the maximum capacity in the Set Mode F13.
Err 10	The tare weight exceeds the maximum capacity of the scale.	Set the tare weight to be smaller than the maximum capacity.
Err 13	The zero value deviates from the set range.	Confirm that there is nothing on the weighing platform. If nothing exists, execute the Calibration in CAL Mode.
Err 14	The gross weight is smaller than the Final weight in Loss-in-batching of the built-in automatic program Mode.	Set the Gross weight to be bigger than the Final weight.
Err 15	The Itemcode range is exceeded in the Command Mode.	Check the ItemCode range.
Err 82	The Error occurs in the A/D conversion part.	Check whether the indicator is properly connected to the load cell.
Over	The weight on the platform is too heavy to be measured.	Do not load the item that exceeds the maximum tolerance. If the load cell is damaged, it should be replaced.

MEMO



NT-580A

Weighing Indicator



CAS BLDG., # 440-1, SUNGNAE-DONG,
GANGDONG-GU, SEOUL, KOREA

TEL_ 82 2 2225 3500

FAX_ 82 2 475 4668

www.globalcas.com